



Rugged Inductive Prox Sensors Meet IP67 Requirements

- Solid potted internal circuitry withstands shocks and water washdown to IP67
- Thick nickel-plated brass barrel has wrench flats for easy installation
- High visibility indicator
- Connector and prewired versions





Ordering Information

■ PRE-WIRED SENSORS

Type	Size	Sensing distance	Part number	
			NO	NC
Shielded 	M12	2 mm	E2E2-X2Y1-US	E2E2-X2Y2-US
	M18	5 mm	E2E2-X5Y1-US	E2E2-X5Y2-US
	M30	10 mm	E2E2-X10Y1-US	E2E2-X10Y2-US
Unshielded 	M12	5 mm	E2E2-X5MY1-US	E2E2-X5MY2-US
	M18	10 mm	E2E2-X10MY1-US	E2E2-X10MY2-US
	M30	18 mm	E2E2-X18MY1-US	E2E2-X18MY2-US

■ SENSORS WITH CONNECTORS

Type	Size	Sensing distance	Part number	
			NO	NC
Shielded 	M12	2 mm	E2E2-X2Y1-M4	E2E2-X2Y2-M4
	M18	5 mm	E2E2-X5Y1-M4	E2E2-X5Y2-M4
	M30	10 mm	E2E2-X10Y1-M4	E2E2-X10Y2-M4
Unshielded 	M12	5 mm	E2E2-X5MY1-M4	E2E2-X5MY2-M4
	M18	10 mm	E2E2-X10MY1-M4	E2E2-X10MY2-M4
	M30	18 mm	E2E2-X18MY1-M4	E2E2-X18MY2-M4

Note: Connector cordsets, use OMRON Y96E-33□A□.

■ ACCESSORIES

Description		Part number
Mounting brackets	Fits M12 size sensors Fits M18 size sensors Fits M30 size sensors	Y92E-B12 Y92E-B18 Y92E-B30
Silicone rubber covers for shielded sensors	Fits M12 size sensors Fits M18 size sensors Fits M30 size sensors	Y92E-E12-2 Y92E-E18-2 Y92E-E30-2
Connector cordsets	See Y96E Connector Cordsets data sheet for details	

■ REPLACEMENT PARTS

Description		Part number
Mounting hardware including one pair of metal nuts and one washer	Fits M12 size sensors Fits M18 size sensors Fits M30 size sensors	M12-MHWS M18-MHWS M30-MHWS

Specifications

Part number	E2E2-X2Y□-US	E2E2-X5M□-US	E2E2-X5Y□-US	E2E2-X10MY□-US	E2E2-X10□-US	E2E2-X18MY□-US
Size	M12		M18		M30	
Type	Shielded	Unshielded	Shielded	Unshielded	Shielded	Unshielded
Sensing distance	2 mm (0.08 in) ±10%	5 mm (0.20 in) ±10%	5 mm (0.20 in) ±10%	10 mm (0.39 in) ±10%	10 mm (0.39 in) ±10%	18 mm (0.71 in) ±10%
Supply voltage (operating voltage range) (See Note 1.)	24 to 240 VAC, 50/60 Hz (20 to 264 VAC)					
Leakage current	1.7 mA max.					
Sensing object	Magnetic metals					
Setting distance	0 to 1.6 mm (0 to 0.06 in)	0 to 4.0 mm (0 to 0.16 in)	0 to 4.0 mm (0 to 0.16 in)	0 to 8.0 mm (0 to 0.31 in)	0 to 8.0 mm (0 to 0.31 in)	0 to 14.0 mm (0 to 0.55 in)
Standard object (mild steel)	12 x 12 x 1 mm (0.47 x 0.47 x 0.04 in)	15 x 15 x 1 mm (0.59 x 0.59 x 0.04 in)	18 x 18 x 1 mm (0.71 x 0.71 x 0.04 in)	30 x 30 x 1 mm (1.18 x 1.18 x 0.04 in)	30 x 30 x 1 mm (1.18 x 1.18 x 0.04 in)	54 x 54 x 1 mm (2.13 x 2.13 x 0.04 in)
Differential travel	10% max. of sensing distance					
Response frequency	25 Hz					
Operation (with sensing object approaching)	Y1 models: Load ON Y2 models: Load OFF					
Control output (switching capacity)	5 to 200 mA		5 to 300 mA (see note 2)			
Indicator	Operation indicator (red LED)					
Ambient temperature	Operating	-40°C to 85°C (-40°F to 185°F) with no icing				
Ambient humidity	Operating	Operating: 35% to 95%				
Temperature influence	±15% max. of sensing distance at 23°C in temperature range of -40°C to 85°C (-40°F to 185°F) ±10% max. of sensing distance at 23°C in temperature range of -25°C to 70°C (-13°F to 158°F)					
Voltage influence	±1% max. of sensing distance in rated voltage range ±15%					
Residual voltage	Refer to <i>Engineering Data</i>					
Insulation resistance	50 MΩ min. (at 500 VDC) between current carry parts and case					
Dielectric strength	4,000 VAC for 1 min. between current carry parts and case					
Vibration resistance	10 to 55 Hz, 1.5-mm double amplitude for 10 times each in X, Y, and Z axes					

(This table continues on the next page.)

Specifications Table - continued from previous page

Part number	E2E2-X2Y□-US	E2E2-X5M□-US	E2E2-X5Y□-US	E2E2-X10MY□-US	E2E2-X10□-US	E2E2-X18MY□-US
Shock resistance	1,000 m/s ² (approx. 100G) for 10 times each in X, Y, and Z axes					
Enclosure rating	IEC	IP67				
	NEMA	1, 4, 6, 12, 13				
Weight	65 g		150 g		220 g	
	Approvals	UL	Recognized, File Number E76675			
	CSA	Certified, File Number LR45951				
Material	Body	Brass				
	Sensing face	PBT				

- Note: 1. When using an M18 or M30 size E2E2 at an ambient temperature between 70°C and 85°C (158°F to 185°F), make sure the E2E2 has a control output of 200 mA maximum.
2. When supplying 24 VAC to any of the above models, make sure that the operating ambient temperature range is -25°C to 85°C (-13°F to 185°F).

Operation

OUTPUT CIRCUIT

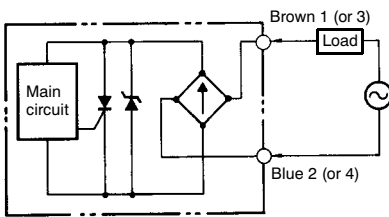

TIMING CHART

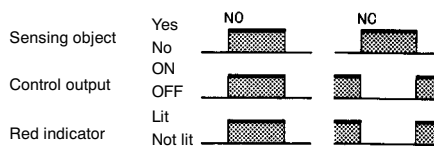

Engineering Data

OPERATING RANGE (TYPICAL)

Shielded Models E2E2-X□Y□

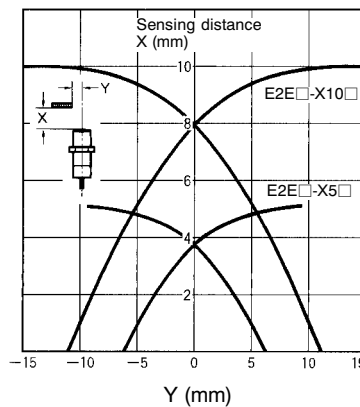
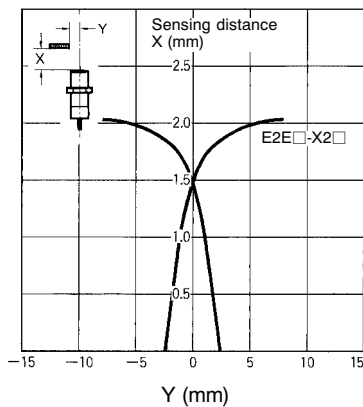

Unshielded Models E2E2-X□MY□

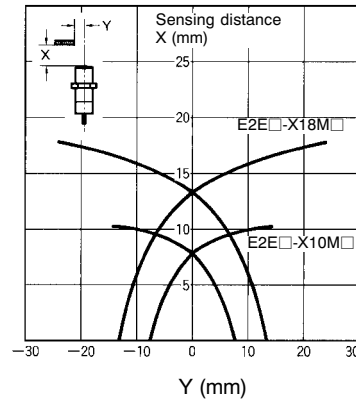
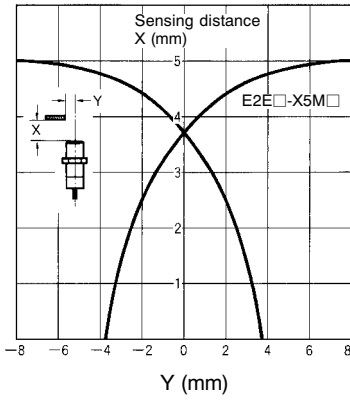

LEAKAGE CURRENT (TYPICAL)

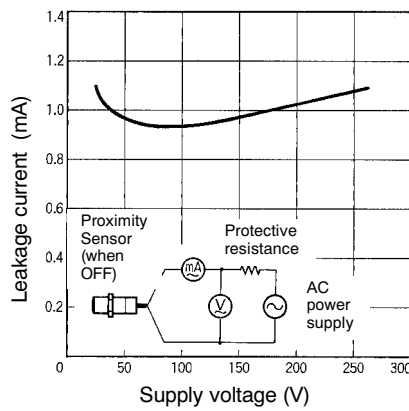

RESIDUAL OUTPUT VOLTAGE (TYPICAL)

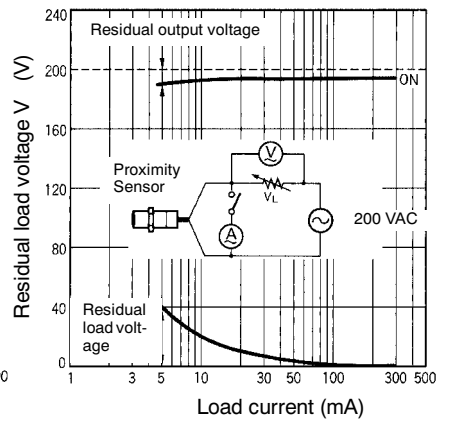
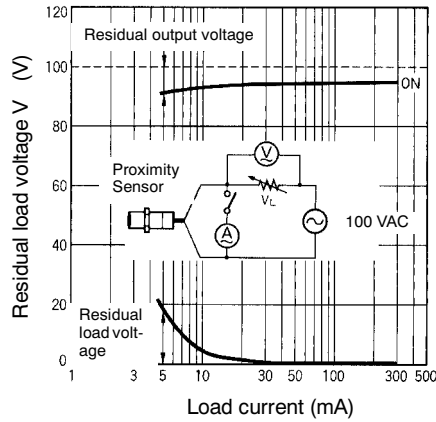
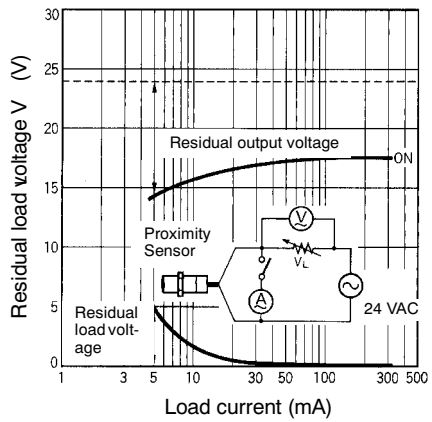

■ SENSING DISTANCE VS. SENSING OBJECT (TYPICAL)

E2E2-X2Y□

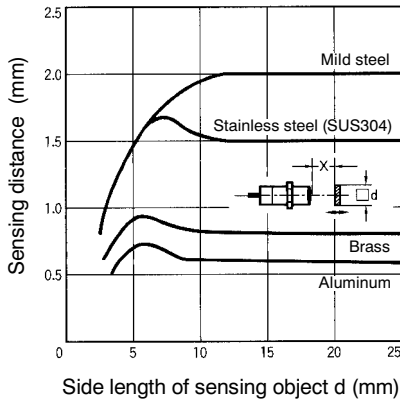

E2E2-X5Y□

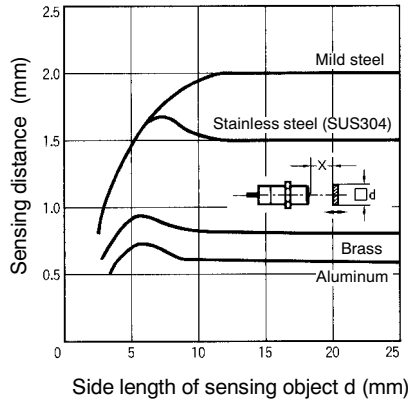

E2E2-X10Y□

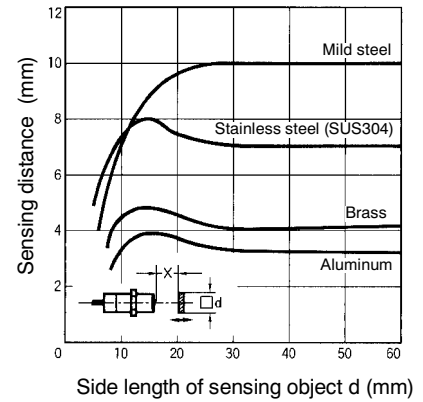

E2E2-X5MY□

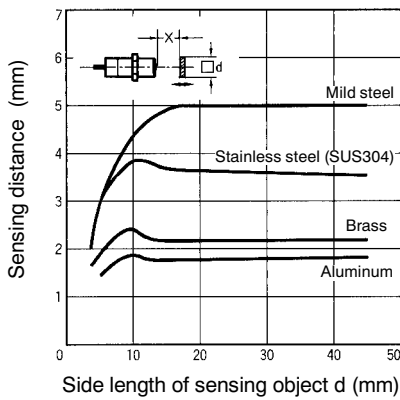

E2E2-X10MY□

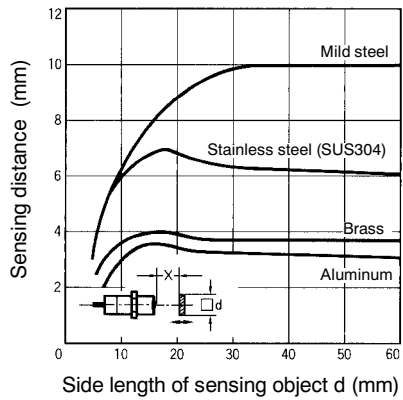

E2E2-X18MY□

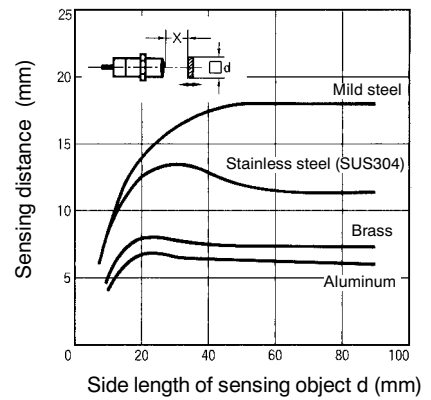

Dimensions

Unit: mm (inch)

■ PRE-WIRED SENSORS

E2E2-X2□□

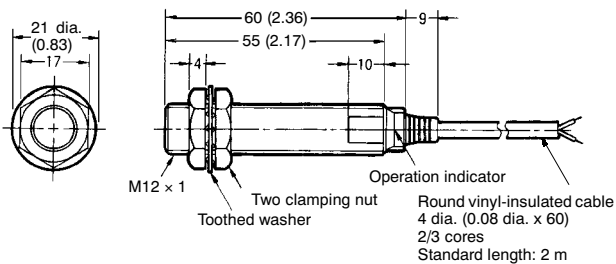

E2E2-X5M□□

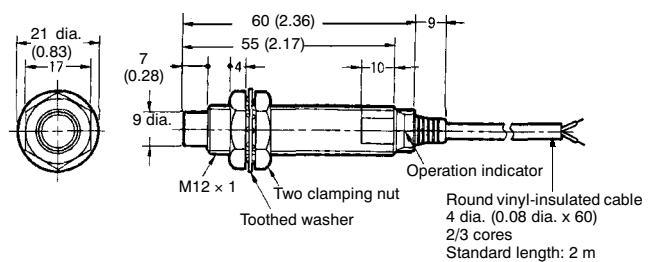

E2E2-X5□□

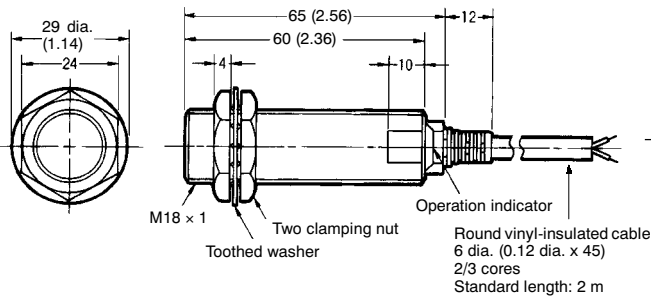

E2E2-X10M□□

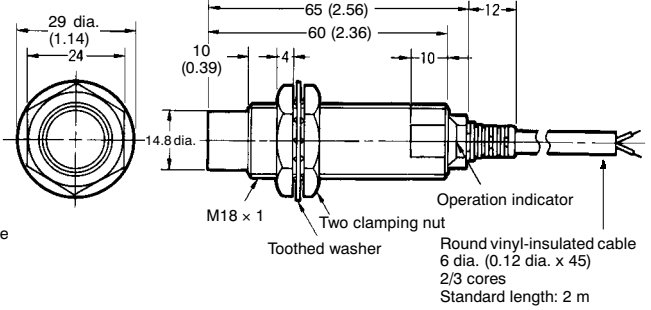

E2E2-X10□□

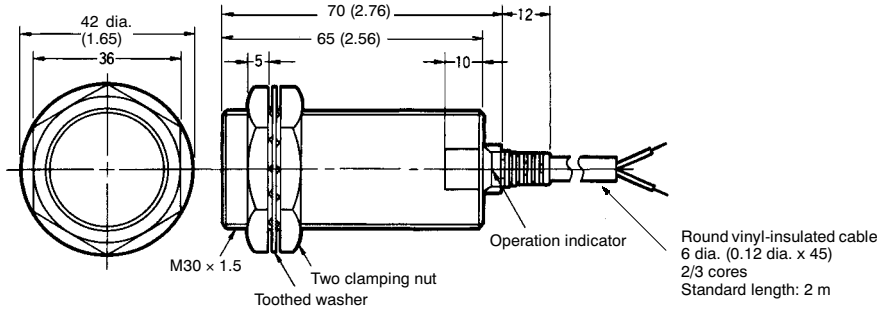

E2E2-X18M□□

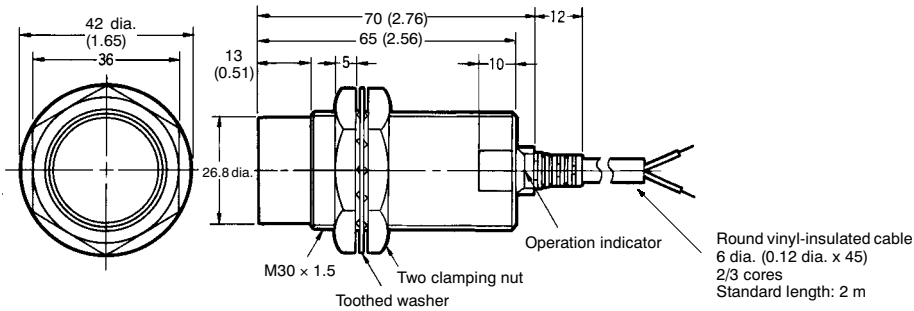

■ SENSORS WITH CONNECTORS

E2E2-X2Y□-M4

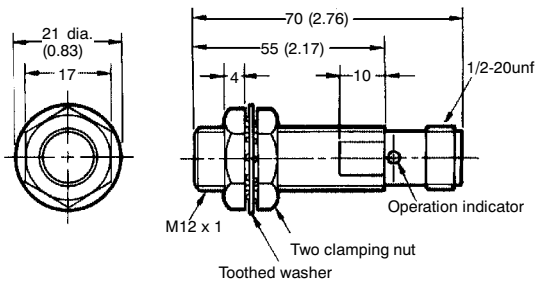

E2E2-X5MY□-M4

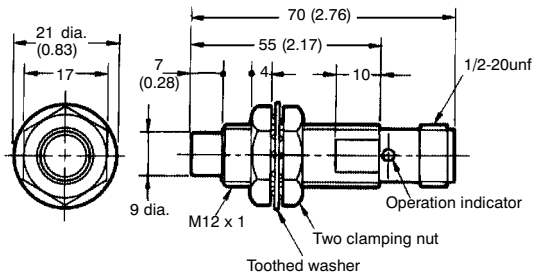

E2E2-X5Y□-M4

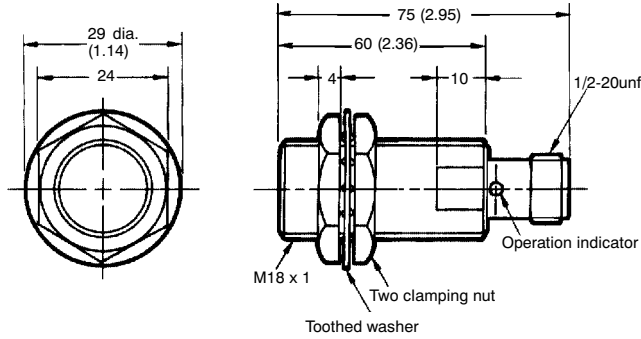

E2E2-X10MY□-M4

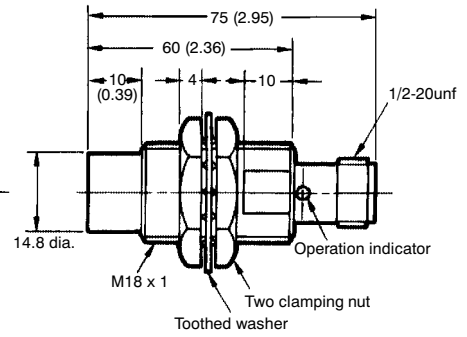

E2E2-X10Y□-M4

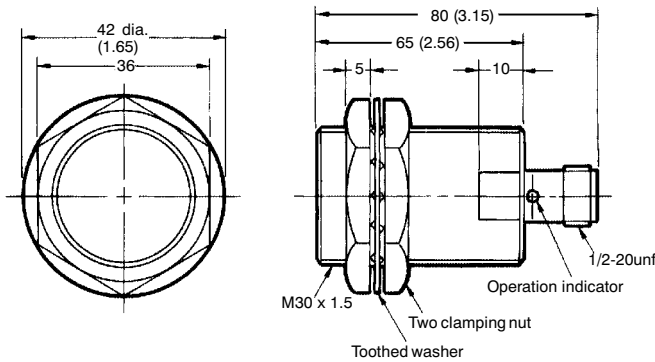

E2E2-X18MY□-M4

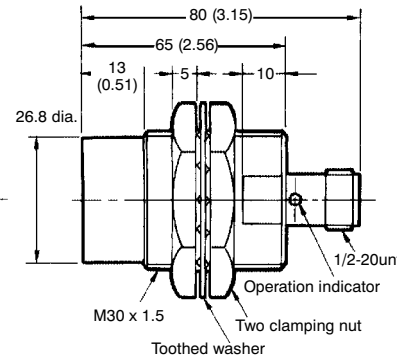

■ MOUNTING HOLES

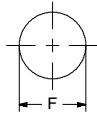

Dimensions	M12	M18	M30
F (mm)	12.5 mm (0.49 in) dia.	18.5 mm (0.73 in) dia.	30.5 mm (1.20 in) dia.

Installation

■ PIN ARRANGEMENT

E2E2-X□Y□-M4

Applicable models	Pin arrangement
E2E2-X□Y□-M4	

■ MOUNTING

Do not tighten the nut with excessive force. A washer must be used with the nut.

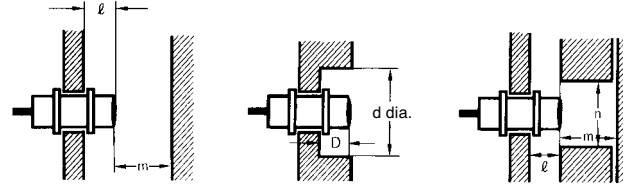
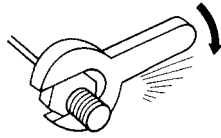

Shielded Model

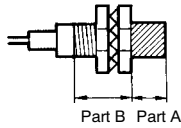

Unshielded Model

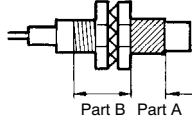

Note: The table below shows the tightening torques for part A and part B nuts. In the previous examples, the nut is on the sensor head side (part B) and hence the tightening torque for part B applies. If this nut is in part A, the tightening torque for part A applies instead.

Type	Torque
M12	30 N • m (310 kgf • cm)
M18	70 N • m (710 kgf • cm)
M30	180 N • m (1,800 kgf • cm)

■ EFFECTS OF SURROUNDING METAL

When mounting the E2E2 within a metal panel, ensure that the clearances given in the table below are maintained. Failure to maintain these distances may cause deterioration in the performance of the sensor.

Type	Dimension	M12	M18	M30
Shielded	l	0 mm	0 mm	0 mm
	d	12 mm	18 mm	30 mm
	D	0 mm	0 mm	0 mm
	m	8 mm	20 mm	40 mm
	n	18 mm	27 mm	45 mm
Unshielded	l	15 mm	22 mm	30 mm
	d	40 mm	55 mm	90 mm
	D	15 mm	22 mm	30 mm
	m	20 mm	40 mm	70 mm
	n	36 mm	54 mm	90 mm

■ MUTUAL INTERFERENCE

When installing two or more Sensors face to face or side by side, ensure that the minimum distances given in the following table are maintained.

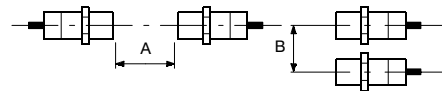

Type	Dimension	M12	M18	M30
Shielded	A	30 mm	50 mm	100 mm
	B	20 mm	35 mm	70 mm
Unshielded	A	120 mm	200 mm	300 mm
	B	100 mm	110 mm	200 mm

Precautions

■ INSTALLATION

Power Reset Time

The Proximity Sensor is ready to operate within 100 ms after power is supplied. If power supplies are connected to the Proximity Sensor and load respectively, be sure to supply power to the Proximity Sensor before supplying power to the load.

Power OFF

The Proximity Sensor may output a pulse signal when it is turned off. Turn off the load before turning off the Proximity Sensor.

Power Supply Transformer

When using a DC power supply, make sure that the DC power supply has an insulated transformer. Do not use a DC power supply with an auto-transformer.

Target Object

Metal Coating

The sensing distances of the Proximity Sensor vary with the metal coating on target objects.

■ WIRING

High-tension Lines

Wiring through Metal Conduit

If there is a power or high-tension line near the cable of the Proximity Sensor, wire the cable through an independent metal conduit to prevent against Proximity Sensor damage or malfunctioning.

Cable Tractive Force

Do not pull cables with the tractive forces exceeding the following.

Diameter	Tractive force
4 mm dia. max.	30 N max.
4 mm dia. min.	50 N max.

■ MOUNTING

The Proximity Sensor must not be subjected to excessive shock with a hammer when it is installed, or the Proximity Sensor may be damaged or lose its water-resistance.

■ ENVIRONMENT

Water Resistance

Do not use the Proximity Sensor underwater, outdoors, or in the rain.

Operating Environment

Be sure to use the Proximity Sensor within its operating ambient temperature range and do not use the Proximity Sensor outdoors so that its reliability and life expectancy can be maintained. Although the Proximity Sensor is water resistant, a cover to protect the Proximity Sensor from water or water-soluble machining oil is recommended so that its reliability and life expectancy can be maintained.

Do not use the Proximity Sensor in an environment with chemical gas (e.g., strong alkaline or acid gasses including nitric, chromic, and concentrated sulfuric acid gasses).

■ CONNECTING LOAD

Refer to the following before using AC 2-wire Proximity Sensors.

Surge Protection

Although the Proximity Sensor has a surge absorption circuit, if there is any machine that has a large surge current (e.g., a motor

or welding machine) near the Proximity Sensor, connect a surge absorber to the machine.

Leakage Current

When the Proximity Sensor is OFF, the Proximity Sensor has leakage current. Refer to Leakage Current Characteristics. In this case, the load is imposed with a small voltage and the load may not be reset. Before using the Proximity Sensor, make sure that this voltage is less than the load reset voltage. The AC 2-wire Proximity Sensor cannot be connected to any card-lift-off relay (e.g., the G2A) because contact vibration of the relay will be caused by the leakage current and the life of the relay will be shortened.

Countermeasures Against Leakage Current

AC 2-wire Models

Connect a bleeder resistor as the bypass for the leakage current so that the current flowing into the load will be less than the load reset current.

As shown in the following diagram, connect the bleeder resistor so that the current flowing into the Proximity Sensor will be 10 mA minimum and the residual voltage imposed on the load will be less than the load reset voltage.

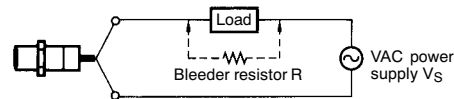

Refer to the following to calculate the bleeder resistance and the allowable power of the bleeder resistor.

$$R \cong V_S / (10 - I) \text{ (k}\Omega\text{)}$$

$$P > V_S^2 / R \text{ (mW)}$$

P: The allowable power of the bleeder resistor. (The actual power capacity of the bleeder resistor must be at least a few times as large as the allowable power of the bleeder resistor.)

I: Load current (mA)

The following resistors are recommended.

100 VAC (supply voltage): A resistor with a resistance of 10 k Ω maximum and an allowable power of 3 W minimum

200 VAC (supply voltage): A resistor with a resistance of 20 k Ω maximum and an allowable power of 10 W minimum

If these resistors generate excessive heat, use a resistor with a resistance of 10 k Ω maximum and an allowable power of 5 W minimum at 100 VAC and a resistor with a resistance of 20 k Ω maximum and an allowable power of 10 W minimum at 200 VAC instead.

NOTE: DIMENSIONS SHOWN ARE IN MILLIMETERS. To convert millimeters to inches divide by 25.4.

OMRON[®]
OMRON ELECTRONICS LLC
One East Commerce Drive
Schaumburg, IL 60173
1-800-55-OMRON

OMRON ON-LINE
Global - <http://www.omron.com>
USA - <http://www.omron.com/oei>
Canada - <http://www.omron.com/oci>

OMRON CANADA, INC.
885 Milner Avenue
Scarborough, Ontario M1B 5V8
416-286-6465