

LW Series (interchangeable parts)

Dimensions of LW Series (Interchangeable ball slide)



Example of reference number

Regular rail (non-butting rail)

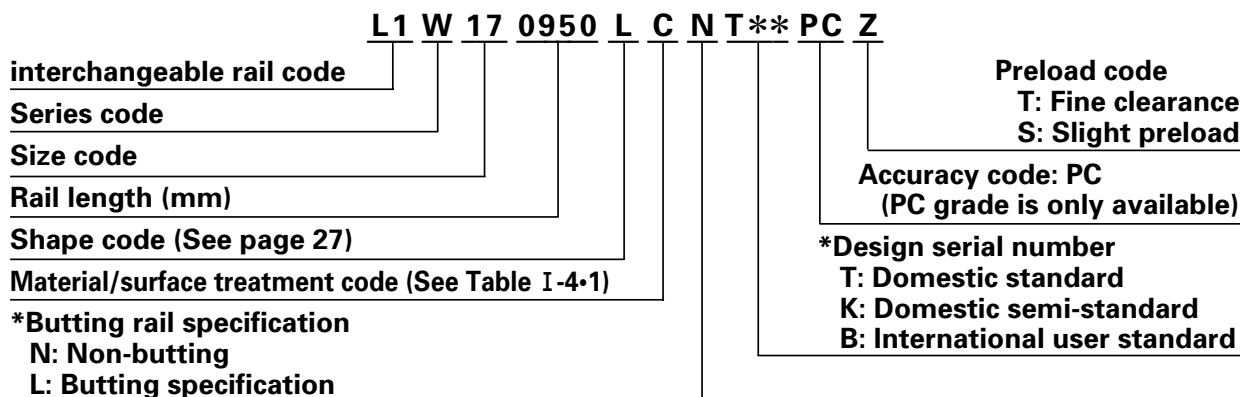

* Please consult with NSK for butting rail specification.

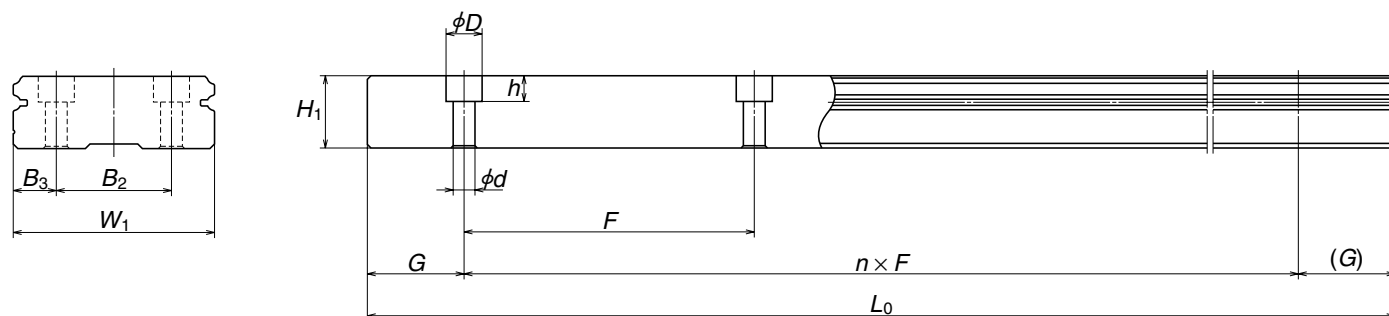

Table. I-5-25

Unit: mm

Model No.	Rail								
	Width W_1	Height H_1	B_2	Pitch F	Mounting bolt hole $d \times D \times h$	B_3	G (recommended)	Max. length L_{0max}	Weight (Kg / m)
L1W17	33	8.7	18	40	4.5×7.5×5.3	7.5	15	1000	2.1
L1W21	37	10.5	22	50	4.5×7.5×5.3	7.5	15	1600	2.9
L1W27	42	15	24	60	4.5×7.5×5.3	9	20	2000	4.7
L1W35	69	19	40	80	7×11×9	14.5	20	2400	9.6
L1W50	90	24	60	80	9×14×12	15	20	3000	15.8