

Manual  
Mini draw wire  
D5.2XXX.24XX  
D5.3501.AXX1

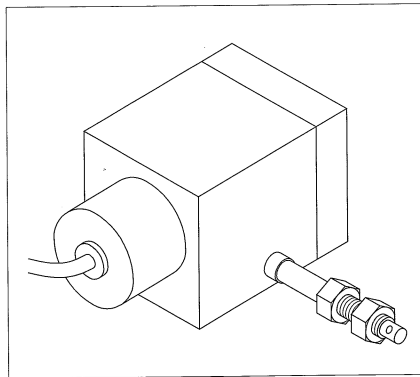

ENGLISH

### 1. Warranty information

- In order to carry out installation correctly, we strongly recommend this document is read very carefully. This will ensure your own safety and the operating reliability of the device.
- Your device has been quality controlled, tested and is ready for use. Please observe all warnings and information which are marked either directly on the device or specified in this document.
- If the system is used together with other products, there is no warranty for the complete system.
- Repairs should be carried out only at our works.

### 2. Identification

Please check the particular type of unit and type number from the identification plate.

### 3. Installation

For mounting, the degree of protection specified must be observed. If necessary, protect the unit against environmental influences such as sprayed water, dust, knocks, extreme temperatures.

The wire actuated transmitter is a high quality measuring device and should be mounted to a flat surface (fig. 1).

- Two M4 threads on the lower surface (max. screw-in depth 8mm) serve to fasten the encoder.

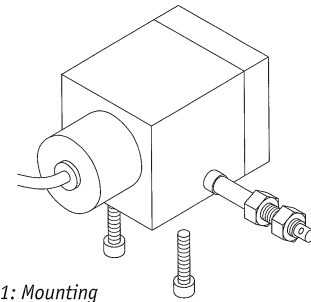

Fig. 1: Mounting

- After mounting, check that the maximum extension length complies with the application (fig. 2).

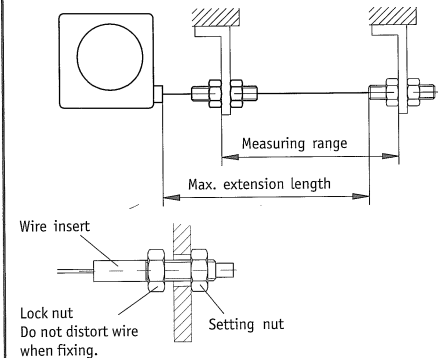



Fig. 2: Extension length check

- The regulating nut serves for fine adjustment. Afterwards the position is fixed by tightening the locknut.

**Attention!** Do not extend the wire beyond the max. allowable extension length and do not twist wire insert. 

#### Wire handling

Pull out the wire perpendicular to the wire outlet (fig. 2).

Do not let the wire go; in every position and during every move the wire must be stretched by the cable drum's spring force.

For correction function the wire must remain without kinks or flattening.

No warranty claim in the case of faulty mounting / laying of the wire.

### Extension wire (accessory)

If necessary an extension wire can be used.



**Attention!** By using an extension wire the maximum measuring length can not be altered. Make sure that the maximum extension length is not exceeded.

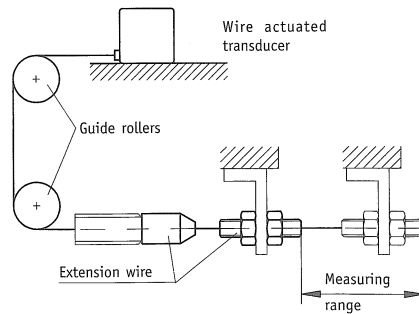

Fig. 3: Extension wire, Guide roller

For mounting the wire extension: Push the connecting piece (3) onto the screw connector (1). The press-fit clamping sleeve (2) will neatly join both elements.

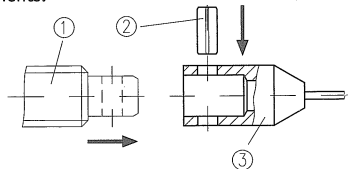

Fig. 4: Mounting of the wire extension

### Guide rollers (accessory)

If the wire cannot be led perpendicularly to the wire outlet, then guide rollers make it possible to pull out the wire in any direction (fig. 3).

- Guide rollers must be mounted in line with the wire.
- Maintain cleanliness of guide rollers at all times.



**Attention:** When using an extension wire make sure that the wire connector does not go over the guide roller.

## 4. Electrical connection

- **Switch power off before any plug is inserted or removed!!**
- Wiring must only be carried out with power off.
- Check all lines and connections before switching on the equipment.

### Interference and distortion

The location should be selected to ensure that no capacitive or inductive interferences can

affect the encoder or the connection lines! Suitable wiring layout and choice of cable can minimise the effects of interference (eg. interference caused by SMPS, motors, cyclic controls and contactors).

### Necessary measures:

- Only screened cable should be used. Put on the cable screen on the control side. Wire cross section is to be at least 0,14mm<sup>2</sup>, max. 0,5mm<sup>2</sup>.
- Wiring to screen and to ground (0V) must be via a good earth point having a large surface area for minimum impedance.
- The unit should be positioned well away from cables with interference; if necessary a **protective screen or metal housing must be provided**. The running of wiring parallel to the mains supply should be avoided.
- Cross section of cables connecting from screen to machine or to control cabinet (GROUND) should be at least 4 mm<sup>2</sup>.

### 4.1 Potentiometer without instrument transformer

Color	Designation
white	Pe End point
green	S Moving contact
brown	Po Start point

### 4.2 Potentiometer with R/I transformer (MWI)

The instrument transformer provides a loop current of 4 ... 20mA.

Color	Designation
brown	I+
white	I-

### 4.3 Potentiometer with R/U transformer (MWU)

The instrument transformer provides an output voltage of 0 ... 10VDC.

Color	Designation
brown	+24VDC
white	GND
green	Uout

### 4.4 Incremental encoder

For the version with incremental encoder take the data from the attached supplementary user information.

## 5. Adjustment and Alignment

### 5.1 Potentiometer setting

When correctly connected and switched on, the unit displays the current actual value.

The measuring range of the potentiometer is matched to the total pull-out length of the wire. Ex works value 00hm is preset for pull-out length 0 mm (wire completely pulled in).

### 5.2 Alignment of the R/I transformer (MWI)

If the device is equipped with a resistance-current converter, then the potentiometer resistance is converted into a current of 4...20mA. The measuring current is also used for feeding the instrument transformer.

Ex works, the instrument transformer is aligned to default values: 4mA for the start position (Po), corresponding to the pull-out length of 0 mm (completely pulled in), and 20mA for the end position (Pe), corresponding to the max. mm pull-out length (completely pulled out) of the potentiometer. **Via two trimmpotentiometer's Po and Pe (see fig. 5) these values can be adjusted to the application's actual start and end position.**

#### Setting the instrument transformer

When the screws are removed (1) and the cover opened (2), the trimming potentiometers can be accessed.

Measuring range  $\leq 1000$

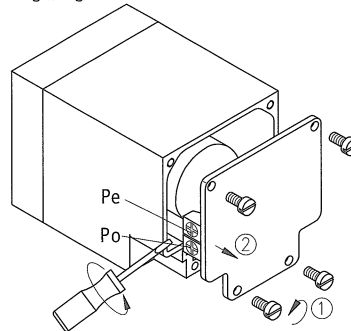

Measuring range  $> 1000$

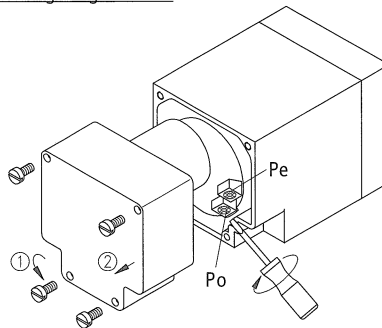

Fig. 5: Setting the trimming potentiometers

- Trimpotentiometer's Po is used to adjust a current of 4 mA to potentiometer values of 0 to 15% of the total range.

- Trimpotentiometer's Pe is used to adjust a current of 20 mA to potentiometer values of 90 to 100% of the total range.

The smallest available potentiometer range, in which 4 to 20 mA are delivered, is hence 15% to 90% of the potentiometer's resistance range.

#### Alignment

- 1) Move axis to start position.
- 2) Turn potentiometer (Po) until start value (4mA) is measured.
- 3) Move axis to end position.
- 4) Turn potentiometer (Pe) until end value (20mA) is measured.

The steps 1 to 4 are to be repeated until the values are counterbalanced.

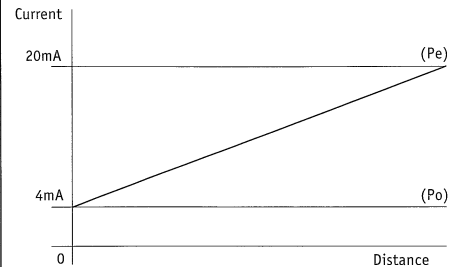

Fig. 6: Alignment

### 5.3 Alignment of the R/U transformer (MWU)

If the device is equipped with a resistance-voltage converter, then the potentiometer resistance is converted into a voltage of 0...10VDC. Connection is via three-wire technology, with the output of the instrument transformer being designed for a current of approx. 5mA.

Ex works, the instrument transformer is aligned to the initial value of 0V output voltage (Po), at an extension length of 0mm and a final value of 10V output voltage (Pe), at a maximum extension length of the encoder. **By means of the trimming potentiometer Pe (see fig. 7), the final value can be adjusted to the actual final position of the application.**

#### Setting the instrument transformer

After loosening the threaded fasteners (1) and opening lid of the housing (2), the trimming potentiometer Pe can be accessed. Since it is SMD designed, it should be set up cautiously. An output

voltage of 10V with an extension position of 60...100% of the maximum encoder extension length can be set.

Measuring range  $\leq 1000$

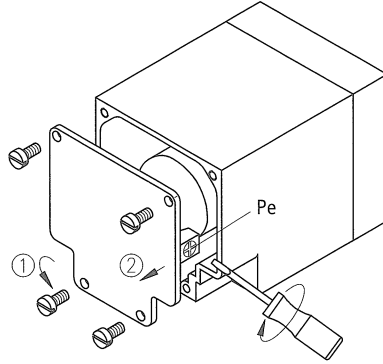

Measuring range  $> 1000$

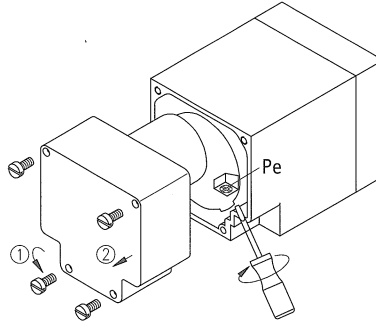

g. 7: Setting the trimming potentiometer

#### Alignment

- 1) Move axis to final position
- 2) Turn potentiometer (Pe) until an output voltage of (10V) is measured.

#### 5.4 Incremental encoder adjustment

When the screws are removed (1) and the cover opened (2), the fixing bolts can be accessed. For adjustment of the reference point the 3 fixing bolts must be loosened to enable turning of the encoder. Turn the encoder in the direction of the arrow until the reference point is reached. Retighten the fixing bolts and mount the cover of the housing.

**Attention!** For adjustment purposes, turn the encoder only counter-clockwise!

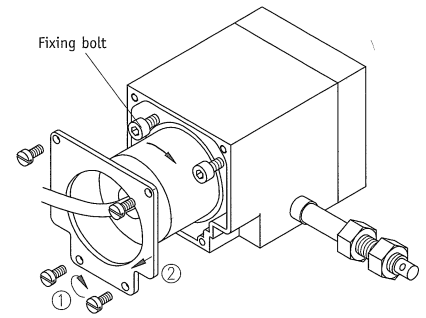

Fig. 8: Adjustment

#### 5.5 What to do if... (Instrument transformer) ... if the instrument transformer's start / end value cannot be set to 4 / 20 mA?

- the potentiometer's setting range is perhaps too small.

#### ... an undefined value is displayed?

- Carry out re-alignment or precise alignment. Undefined values can be caused by cable breaks.

## 6. Starting

Please ensure that the instructions given in chapter 4 and 5 regarding mechanical and electrical connection are followed. This will ensure correct installation and the operating reliability of the device.

Before starting check again:

- correct polarity of the supply voltage
- correct cable connection
- correct mounting of the device