

### Fixed Position Bar Code Reader with Integrated Decoder

- Compact size for confined installations
- Use as a bar code reader or verifier
- Automatically adjusts for deviations in bar code color, quality and reflectance
- Raster functions compensate for poorly printed or damaged labels
- Configurable communications protocol for RS-232, RS-422, RS-485 applications
- FDA, IEC Class II laser light source



### Ordering Information

#### ■ BAR CODE READERS

Description	Part number
BCR with standard optics	V550-A20
BCR with high density optics	V550-A20HD
BCR with standard optics and high speed motor	V550-A20HS
BCR with standard optics and reconstruction technology (DRX)	V550-A20-X
BCR with high density optics and reconstruction technology (DRX)	V550-A20HD-X
BCR with standard optics, high speed motor and reconstruction technology (DRX)	V550-A20HS-X
BCR with standard optics and 1/2" raster at 10"	V550-A20-R0.5
BCR with high density optics and 1/2" raster at 10"	V550-A20HD-R0.5
BCR with standard optics, high speed motor and 1/2" raster at 10"	V550-A20HS-R0.5
BCR with standard optics and 1" raster at 10"	V550-A20-R1
BCR with high density optics and 1" raster at 10"	V550-A20HD-R1
BCR with standard optics, high speed motor and 1" raster at 10"	V550-A20HS-R1

#### ■ ACCESSORIES

Description	Part number
Minature DIN-rail mounting power supply, 3 watts, 5VDC out, 120 VAC in	S82K-00305
Right angle exit attachment	V559-A24
Programming kit (120 VAC)	V559-A25C
Mounting plate	V559-A26A
Cradle mounting bracket	V559-A26B
Picket fence mounting bracket	V559-A26D
Ladder mounting bracket	V559-A26E
Mounting clips	V559-A26F

(This table continues on the next page)

Accessories Table - continued from previous page

Description	Part number
BCR-PLC cable (9-pin RS-232), 2m. Requires external power supply.	V559-A32A-2M
BCR-PLC cable (9-pin RS-232), 5m. Requires external power supply.	V559-A32A-5M
Programming cable (9-pin RS-232), 2m. Requires external power supply.	V559-A32B-2M

## MANUALS

Description	Part number
V550-A20 Operation Manual	Q01BAZ2
V550-A20 Programming Manual (BCSETUP manual) - includes BCSetup software disk	Q02BAZ2

## Specifications

Part Number	V550-A20 V550-A20-X V550-A20-R0.5 V550-A20-R1	V550-A20HD V550-A20HD-X V550-A20HD-R0.5 V550-A20HD-R1	V550-A20HS V550-A20HS-X V550-A20HS-R0.5 V550-A20HS-R1	
Type	Standard	High density	High speed	
Applicable bar code symbols	Detectable bar code types	Code 39, Code 128, UPC-A, UPC-E, EAN-8, EAN-13, Codabar, Interleaved 2 of 5, Straight 2 of 5 (See note 1.), AS-10, 10-bit periodic binary, Code 93, Extensions for UPC and EAN types, Pharmacode (See note 2.).		
	Readable digits	Symbology dependent		
Reading characteristics	Resolution	0.25 mm (0.009 in)	0.13 mm (0.005 in)	0.25 mm (0.009 in)
	Reading distance	25-305 mm (1-12 in)	51-152 mm (2-6 in)	25-305 mm (1-12 in)
	Max. scan window	244 mm (9.6 in)	122 mm (4.8 in)	244 mm (9.6 in)
	Scan rate	500 scans/sec	300 scans/sec	700 scans/sec
	Light source	0.95 mW visible red laser diode; 670 nm wavelength, Class II		
	Decoder	Auto decode installed		
	Skewed label correction	DRX data reconstruction technology on -X models		
	Poor label quality	Raster scanning of 1/2" or 1" at 10" on -R0.5 or -R1 models respectively		
Indicator	Multi-status LED			
Interface	D subminiature male 15 pin connector (RS-232, RS-422, RS-485)			
Programming	External computer or terminal			
Trigger input	5 V TTL or dry contact			
Outputs	2 (open collector - 5 V, 100 mA max.)			
Power supply	5 VDC (4.85 VDC minimum, 5.25 VDC maximum)			
Current consumption	500 mA typical (600 mA maximum)			
Vibration resistance	10 to 150 Hz, 0.5 mm double amplitude for 8 min in each X, Y, and Z direction. Completed 4 times with an acceleration of 7G.			
Shock resistance	20 G, 3 times in each $\pm X$ , $\pm Y$ , and $\pm Z$ directions.			
Weight	142 g (5 oz)			
Environment	Operating temperature	0° to 40°C (32° to 104°F)		
	Operating humidity	10% to 90% non-condensing		
	Enclosure rating	NEMA 12		

Note: 1. Straight 2 of 5 symbology only available on models with DRX.  
2. Pharmacode symbology not available on models with DRX.

(This table continues on the next page)

Specifications Table - continued from previous page

Approvals	UL/CSA	Listed (USA) NRTL/C (Canada) file number E134951 (when used with a UL listed Class II power supply).
	CE	EN60950, EN55022, EN50082-1 (SELV power supply required).
Dimensions	65 mm x 54 mm x 36 mm (2.56 in x 2.14 in x 1.43 in)	
External devices	<ul style="list-style-type: none"> <li>• Interface cable</li> <li>• Power supply</li> <li>• PLC and/or host computer</li> </ul>	

Note: 1. Straight 2 of 5 symbology only available on models with DRX.  
 2. Pharmacode symbology not available on models with DRX.

## Notes

---

### ■ DRX® TECHNOLOGY—X Models

DRX Technology enables the V550-A20 bar code reader to reconstruct an entire bar code from partial scans of that code. Models that include DRX can read labels that non-DRX models may not.

### ■ HIGH DENSITY VERSIONS—HD Models

Models with high density optics are designed to read bar codes with elements as small as 5 mils at a scan rate of 300 scans per second.

### ■ HIGH SPEED VERSION—HS Models

High speed versions are designed to read at speeds up to 700 scans per second and feature a high speed brushless DC motor.

### ■ RASTER VERSIONS—R0.5 and R1 Models

Raster is the process of projecting the laser beam at varied angles spaced evenly from each other. Typically, the mirror wheel surfaces are angled to create multiple scan lines instead of a single beam. Height of the raster feature, when measured at 10" from the optical window, is either 1/2" or 1" depending on the model.

# Engineering Data

## OPERATING RANGE CHARTS

### V550-A20

Narrow element width	Reading distance	Maximum scan window
10.0 mil (0.25 mm)	2.5"-6.0" (64-153 mm)	4.8" (122 mm)
15.0 mil (0.38 mm)	1.0"-7.0" (25-178 mm)	5.6" (142 mm)
20.0 mil (0.5 mm)	1.0"-9.0" (25-228 mm)	7.2" (183 mm)
30.0 mil (0.76 mm)	1.0"-11.0" (25-279 mm)	8.8" (224 mm)
≥40.0 mil (1 mm)	1.0"-12.0" (25-305 mm)	9.6" (244 mm)

Scan Rate: 500 scans per second

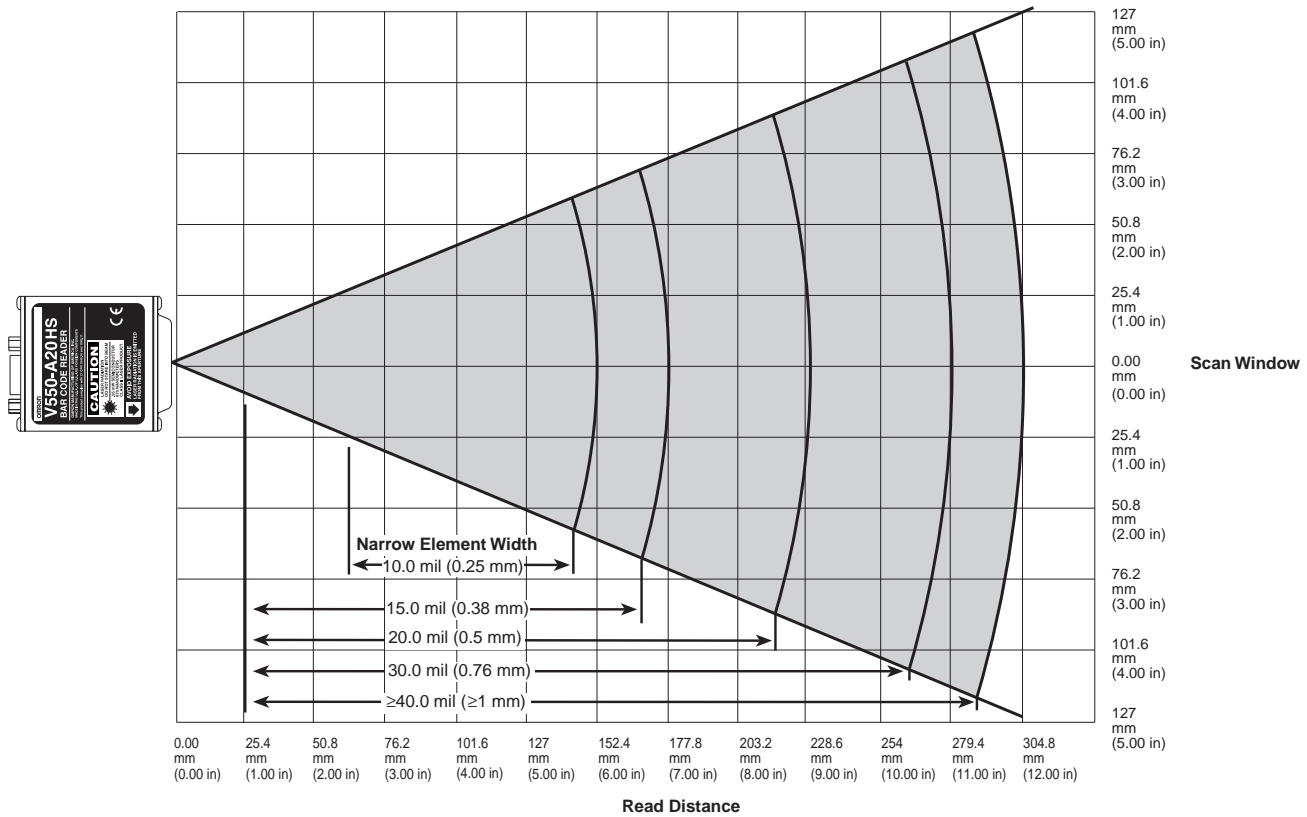

Note: These read ranges were obtained using quality bar codes (rated 'A' by ANSI standards). Results may vary depending on quality of bar codes.

**V550-A20HS**

Narrow element width	Reading distance	Maximum scan window
10.0 mil (0.25 mm)	2.5"-5.0" (64-127 mm)	4.0" (102 mm)
15.0 mil (0.38 mm)	1.0"-7.0" (25-178 mm)	5.6" (142 mm)
20.0 mil (0.5 mm)	1.0"-9.0" (25-228 mm)	7.2" (183 mm)
30.0 mil (0.76 mm)	1.0"-11.0" (25-279 mm)	8.8" (224 mm)
≥40.0 mil (1 mm)	1.0"-12.0" (25-305 mm)	9.6" (244 mm)

Scan Rate: 700 scans per second

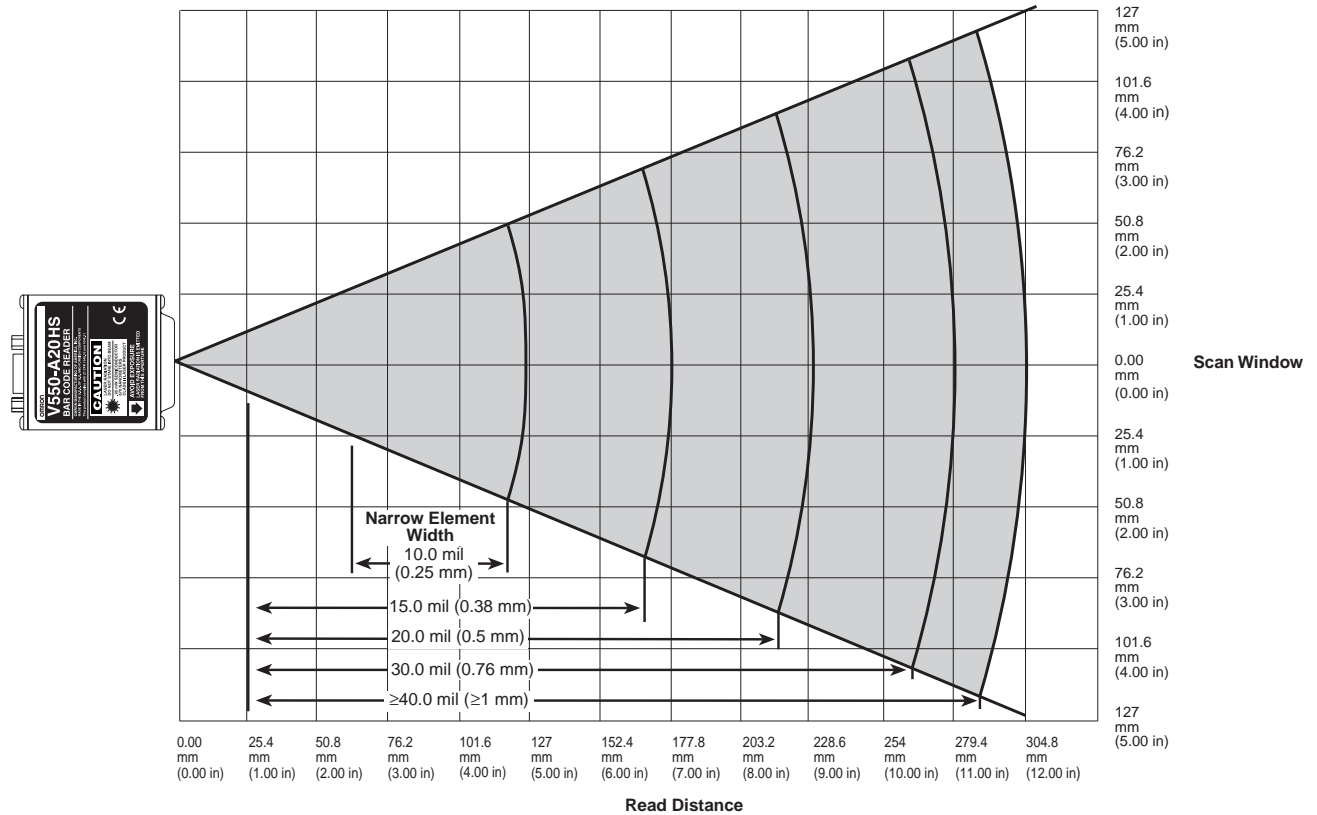

Note: These read ranges were obtained using quality bar codes (rated 'A' by ANSI standards). Results may vary depending on quality of bar codes.

### V550-A20HD

#### Standard Scan Head—Optical Performance (Model V550-A20)

Narrow element width	Reading distance	Maximum scan window
5.0 mil (0.13 mm)	2.0"-4.0" (51-102 mm)	3.2" (81 mm)
7.5 mil (0.19 mm)	2.0"-4.25" (51-108 mm)	3.4" (86 mm)
10.0 mil (0.25 mm)	2.0"-4.5" (51-114 mm)	3.6" (91 mm)
15.0 mil (0.38 mm)	2.0"-5.0" (51-127 mm)	4.0" (102 mm)
≥20.0 mil (≥0.51 mm)	2.0"-6.0" (51-152 mm)	4.8" (122 mm)

Scan Rate: 300 scans per second

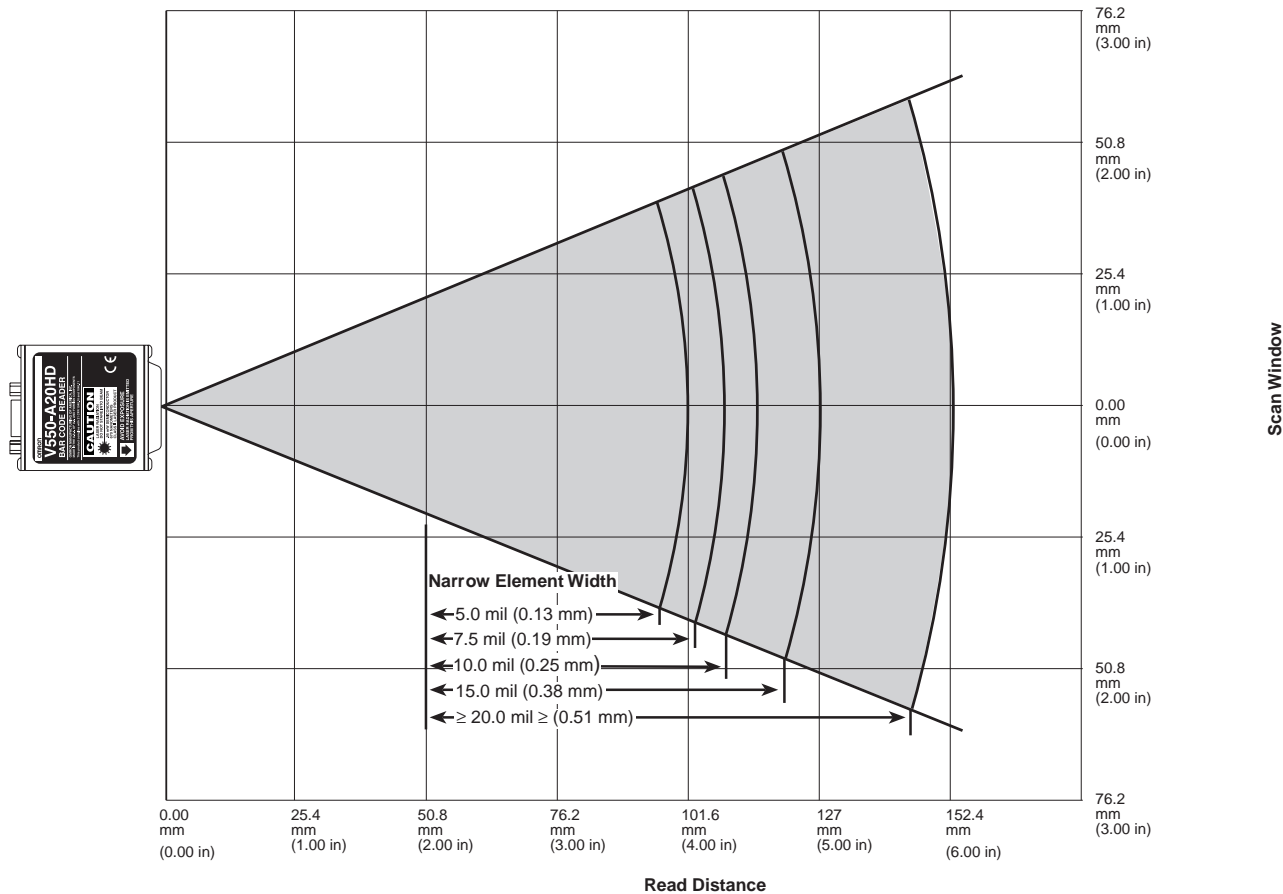

Note: These read ranges were obtained using quality bar codes (rated 'A' by ANSI standards). Results may vary depending on quality of bar codes.

# Connection

## ■ V550-A20 PIN ALLOCATION

Pin No.	Signal	Description
1	GND	Signal ground
2	TXD	Transmit data (RS-232)
3	RXD	Receive data (RS-232)
4	OUT 0	NVC/No match output
5	OUT 1/CTS/TACH	GO/Match output/Clear to send (RS-232)/ Tachometer connection
6	SD+	Send data (RS-422)/Non-inverting line (RS-485)
7	RD+	Receive data (RS-422)
8	SD-	Send data (RS-422)/Inverting line (RS-485)
9	RD-	Receive data (RS-422)
10	N/C	No connection
11	GND	Ground
12	Analog code	Analog signal output
13	Trigger	Trigger input
14	+5V	Power input
15	+5V	Power input

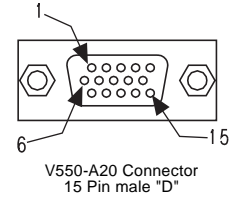

## ■ PINOUT DIAGRAMS

### RS-232 With No Handshaking

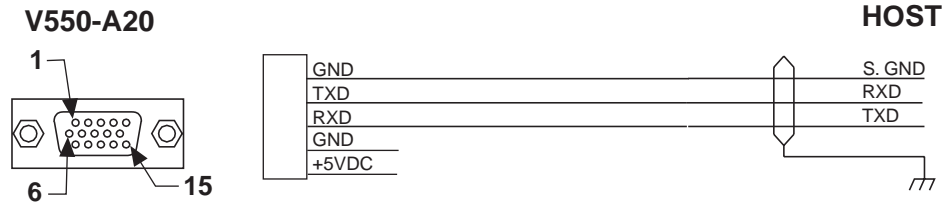

### RS-422 (Point to Point)

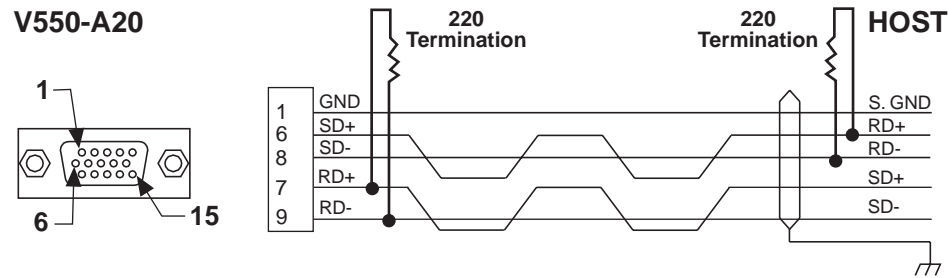

Note: Termination resistors may be placed inside the connector strain relief. The termination resistor value is 220 OHM, 1/4 watt. With RS-422, the receive lines on both sides must be terminated.

RS-232 With RTS/CTS Handshaking

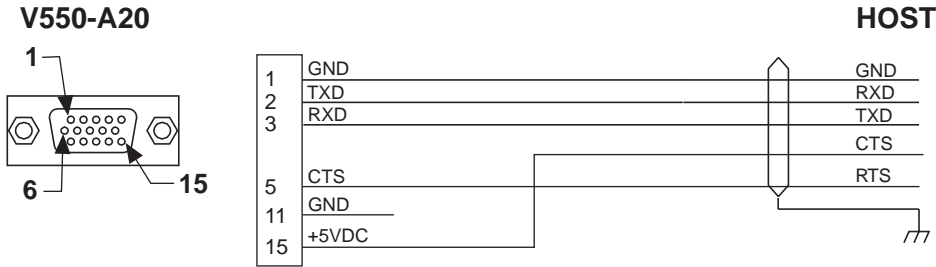

RS-485 Multipdrop

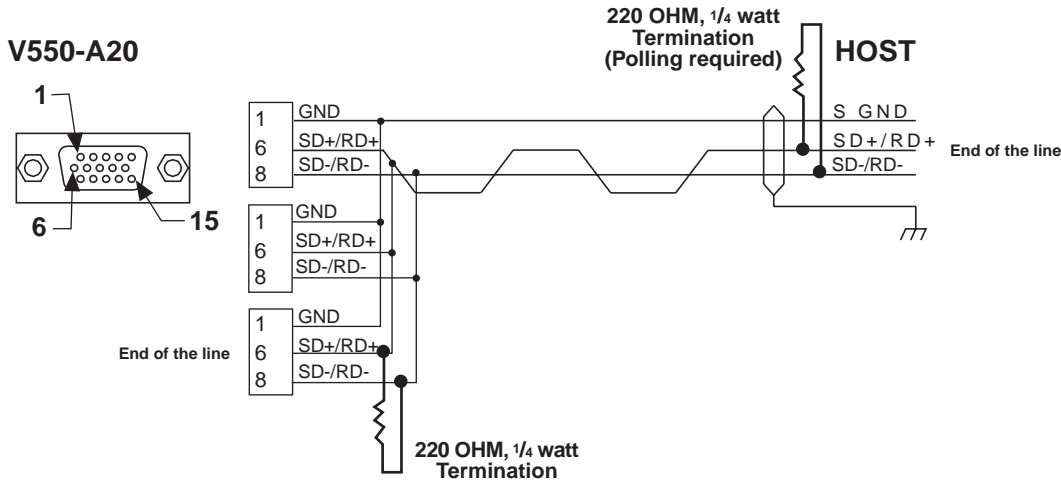

Note: RS-485 allows for communication across the same lines. Termination resistors can be placed inside the connector strain relief. The transmit-receive lines on both sides must be terminated.

V559-A25C Programming Kit

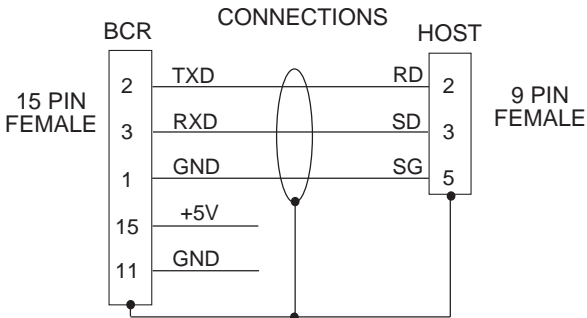

V559-A32A BCR-PLC Cable (9-pin RS-232)

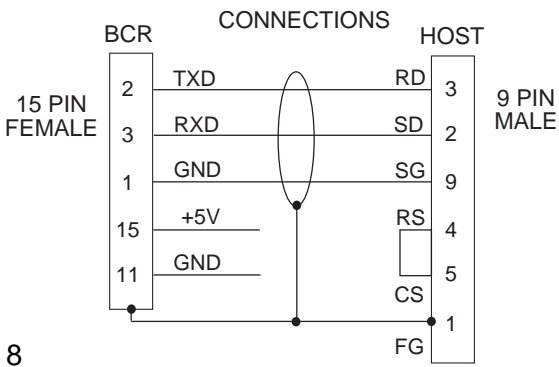

V559-A32B

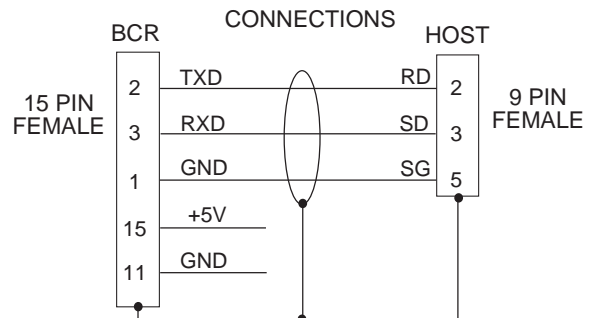

# Configuration

## ■ SETTING UP BCR WITH PERSONAL COMPUTER

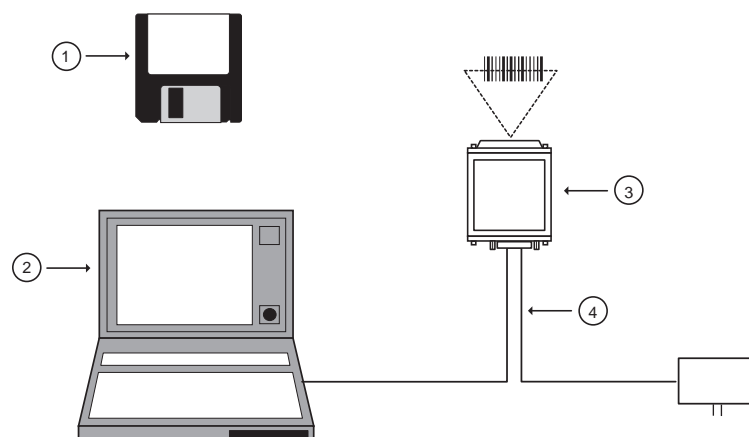

①	Configuration software	BCSETUP
②	Laptop computer	
③	Bar code reader	V550-A20
④	Programming kit	V559-A25C

## ■ INSTALLING BCSETUP CONFIGURATION SOFTWARE

To install BCSetup on PC's hard drive, follow instructions on diskette label.

## ■ TEST SETUP PROCEDURE

### To retrieve settings from device:

- Confirm that the bar code reader (BCR) is communicating with device. Select menu option "Retrieve Setup from Device" and press <Enter>.

### To change the No Read Message to question marks:

- Select the menu option "Communication Setup" and use the down arrow key to highlight the "No Read Message" selection.
- Enter "?". Delete any remaining message. Press <Esc> to return to the Main Menu.

### To deactivate code quality functions:

- Select the menu option "Communication Setup" and use the down arrow key to highlight the "Delimiter Between Data and Code Quality" selection.
- Enter "X". Press <Esc> to return to the Main Menu.

### To change the Trigger to Serially Controlled Trigger:

- Select the menu option "Trigger Setup" and use the down arrow key to highlight the "Scanner Trigger Type" selection.
- Use <space bar> to toggle through choices until "Serially Controlled" is selected. Press <Esc> to return to the Main Menu.

### To change the Bar Code to 8 character Code 39 with no Modulus Check:

- Select the menu option "Bar Code Setup" and highlight the "Bar Code #1" selection.
- Use <space bar> to toggle to "Code 39".
- Press down arrow key (or <Enter>) once to highlight "Number of Characters" selection. Enter "00" in "Number of Characters" selection.
- Highlight "Modulus Check Character" selection. Toggle to "Disabled".
- Press <Esc> to return to Main Menu.

### To program the V550-A20 with the new settings:

- Select the menu option "Program Mode" and highlight "Select Programming Command".
- Toggle to "Transfer Settings to Device and Use". (Note: settings will remain active until unit is powered down. When power is restored, original settings will be in effect.)
- Press <Enter>.
- Press <Esc> to return to Main Menu.

### To read sample bar codes from this datasheet:

- Select menu option "CRT Mode" and press <Enter>.
- Press S (upper case) to start trigger cycle and turn on laser.
- Hold sample Code 39 bar code in front of BCR.
- Press E (upper case) to end trigger cycle and turn off laser.
- The bar code reader will send the bar code message (along with a space and the number of times it read the bar code) to the computer screen.

# PLC Connection Examples

## ■ SYSMAC SERIES CQM1 CONTROLLER WITH RS-232 CONNECTION

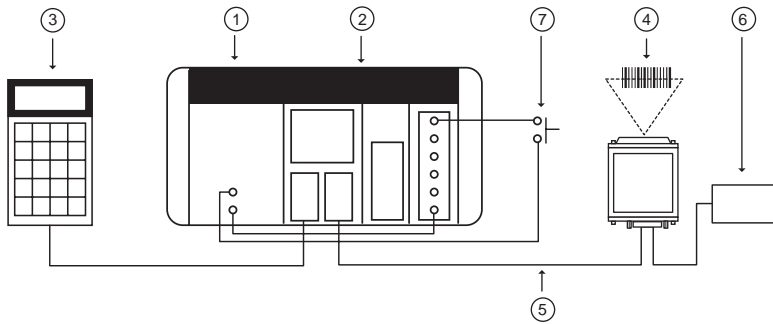

①	Power supply unit	CQM1-PA206
②	CPU unit	CQM1-CPU21
③	Programming console	CQM1-PRO
④	Bar code reader	V550-A20
⑤	Connecting cable	V559-A32A-2M
⑥	BCR power supply	S82S-0305 (5V, 0.6A) (see note)
⑦	Trigger switch	Relay or switch

Note: Not rated for UL Class II operation.

### ■ OPERATION

Switch ON trigger switch ⑦ shown above to execute V550-A20 to read and send data to the data memory area of CQM1. Use the program console ③ to confirm the data. In the event the data was not read, press "?" after the trigger switch is OFF.

### ■ V550-A20 SETUP

- Communication condition (setup):  
 Baud rate: 9600 bps  
 Word length: 7 bit  
 Parity: EVEN  
 Stop bit: 2 bit

- Trigger Requirements:  
 Start code: S  
 Stop code: E  
 Data output mode: Single output  
 Scan trigger type: Serially controlled  
 Trigger stage: Standard

### ■ CQM1 SETUP

- Communication condition:  
 Set OFF dip switch 5 of CQM1 and set [1000] on DM6645 to match the communication condition with BCR (refer to the CQM1 programming manual for the detailed way to change the condition).
- Setting of Start code and Stop code:  
 Set [2000] on DM6648.
- On the DM, set the ASCII code [S] to Start Reading and [E] to Stop Reading.
- Connection of trigger switch:  
 Connect the trigger switch to the input port [00000] terminal on the CPU unit to be able to send [S] or [E] through the RS-232C line when the BCR is ON or OFF, respectively.
- Save the received data from the BCR in the order from upper digit, DM0200 must be the top, to down.

### ■ CONFIRMATION OF OPERATION

- After programming, set RUN mode and set the trigger switch ON to execute the reading with the LED on the BCR lighting.
- Press the key in the order below in order to confirm the data with the console:  
 ① CLEAR → ② FUN → ③ MONITOR
- The "?" is indicated, in the event that the data can't be read until the trigger switch is OFF.

### ■ CQM1 PROGRAMMING

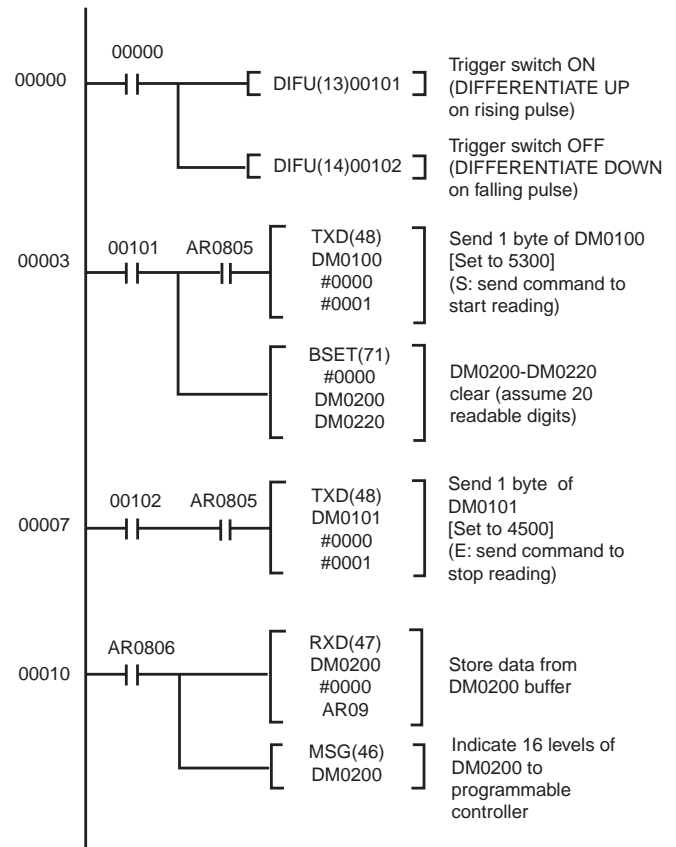

## ■ SYSMAC SERIES C200HS OR C200H ALPHA WITH RS-232 CONNECTION:

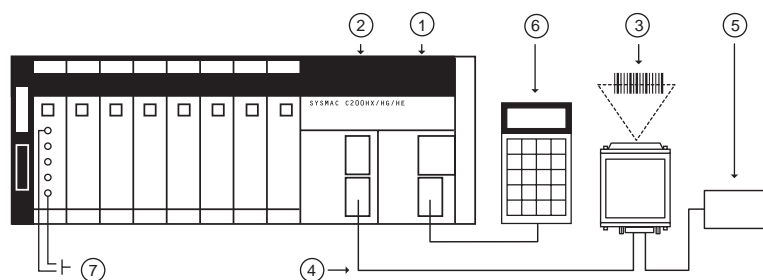

①	CPU unit	C200HS-CPU21
②	Communications board	C200HW-COM04, C200HW-COM05
③	Bar code reader	V550-A20
④	Connecting cable	V559-A32A-2M
⑤	Power supply	S82S-0305 (5V, 0.6A) (see note)
⑥	Programming console	C200H-PRO27
⑦	Trigger switch	

Note: Not rated for UL Class II operation.

## ■ OPERATION

Switch ON trigger switch ⑦ shown above to execute V550-A20 to read and send data to the data memory area of C200□. Use the program console ⑥ to confirm the data. In the event the data was not read, press "?" after the trigger switch is OFF.

## ■ V550-A20 SETUP

- Communication condition (setup):
  - Baud rate: 9600 bps
  - Word length: 7 bit
  - Parity: EVEN
  - Stop bit: 2 bit
- Trigger Requirements:
  - Start code: S
  - Stop code: E
  - Data output mode: Single output
  - Scan trigger type: Serially controlled
  - Trigger stage: Standard

## ■ C200HS OR C200Hα SETUP

- Communication condition:
  - Set OFF dip switch 5 of C200HS or C200Hα and set [1000] on DM6645 to match the communication condition with BCR (refer to the Reference Manual for the detailed way to change the condition).
- Setting of Start code and Stop code:
  - Set [2000] on DM6648.
- On the DM, set the ASCII code [S] to Start Reading and [E] to Stop Reading.
- Connection of trigger switch:
  - Connect the trigger switch to the input port [00000] terminal on the CPU unit to be able to send [S] or [E] through the RS-232C line when the BCR is ON or OFF, respectively.
- Save the received data from the BCR in the order from upper digit, DM0200 must be the top, to down.

## ■ CONFIRMATION OF OPERATION

- After programming, set RUN mode and set the trigger switch ON to execute the reading with the LED on the BCR lighting.
- Press the key in the order below in order to confirm the data with the console:
  - ① CLEAR → ② FUN → ③ MONITOR
- The "?" is indicated, in the event that the data can't be read until the trigger switch is OFF.

## ■ C200HS OR C200Hα PROGRAMMING

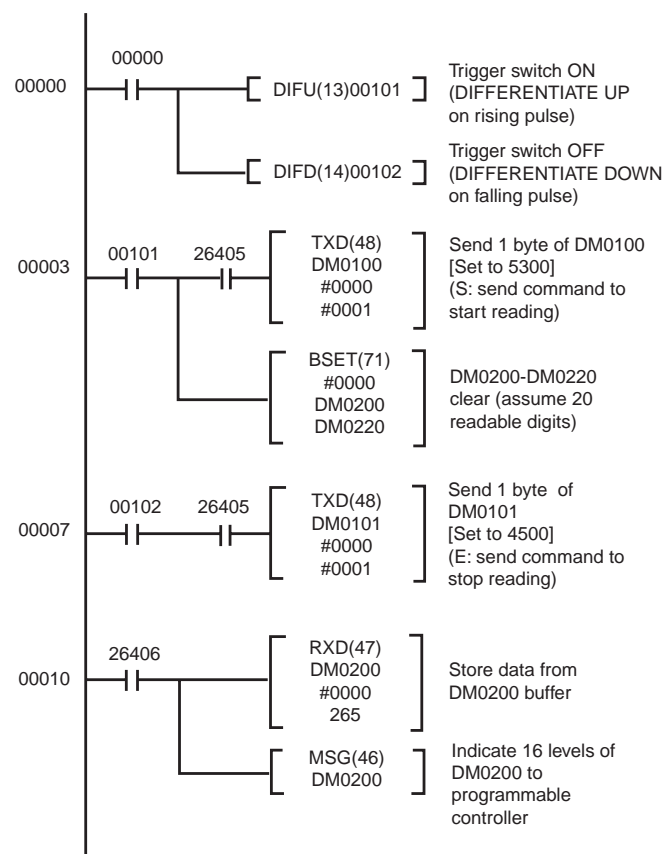

# PLC Master/Slave System

## ■ SYSMAC SERIES C200Hα . . . RS-485 MULTIDROP

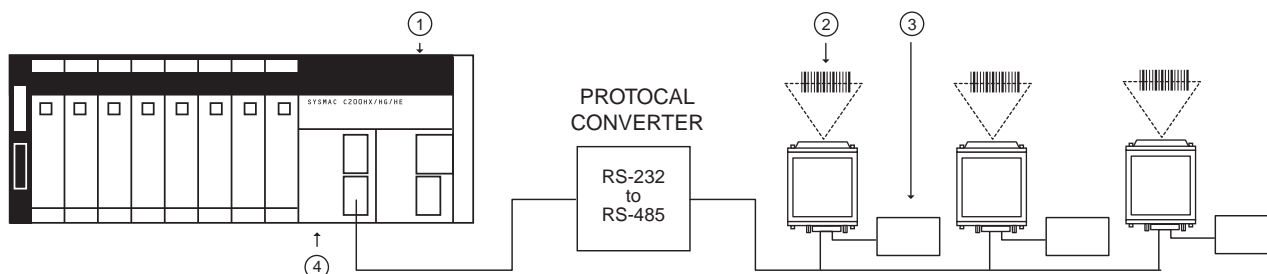

①	CPU	C200H . . .
②	Bar code reader	V550-A20
③	Power supply unit	S825-0305 (5V, 0.6A) (see note)
④	Communications board	C200HW-COM04, C200HW-COM05

Note: Each bar code reader requires a minimum of 500 mA to operate. If your system contains more than 1 bar code reader in parallel, select a power supply rated for a higher output current.

### ■ CONNECTION WITH MULTIPLE READERS:

Up to 32 slaves can be connected for each serial port on the master (depending upon line length and required response time).

- Operation:  
The master device, C200H . . . , sends poll messages to the slave BCRs requesting them to respond with data. The BCRs respond to the polls. There is no response if they are not polled by the master.

- Message formats:

#### V550-A20 Communication setting

Basic setting	READ trigger	Level trigger
	Read mode	Single
Communication	Baud rate	9600 bps
Condition (default)	Word length	7 bit
	Parity	EVEN
	Stop bit	2 bit
	Header	STX
	Footer	CR
	RS/CS Control	OFF

Framing for all messages sent by any device on the multidrop line: FF, STX, ID, TYPE, SEQ, DATA, LRC, CR.

Code	Description	Notes
FF (hex)	Guard character	Ignored by receiver
STX (02hex)	Start of text character	Indicates start of a message
ID (2 ASCII digits)	Unit identifier	Indicates BCR identification number
TYPE (2 ASCII digits)	Message type	Describes purpose of the message
SEQ	Sequence number	Starts at 0 at power up; incremented by 1 for each data message sent
DATA	Content of data field	May or may not contain characters
LRC (2 ASCII digits)	Linear redundancy check	Checks to ensure that message is valid
CR	Carriage return	Indicates end of message

■ **C200Hα COMMUNICATIONS BOARD CONNECTIONS:**

The connections from the bar code reader connectors to the C200Hα COM board are shown below.

**V550-A20**

**Bar Code Reader**

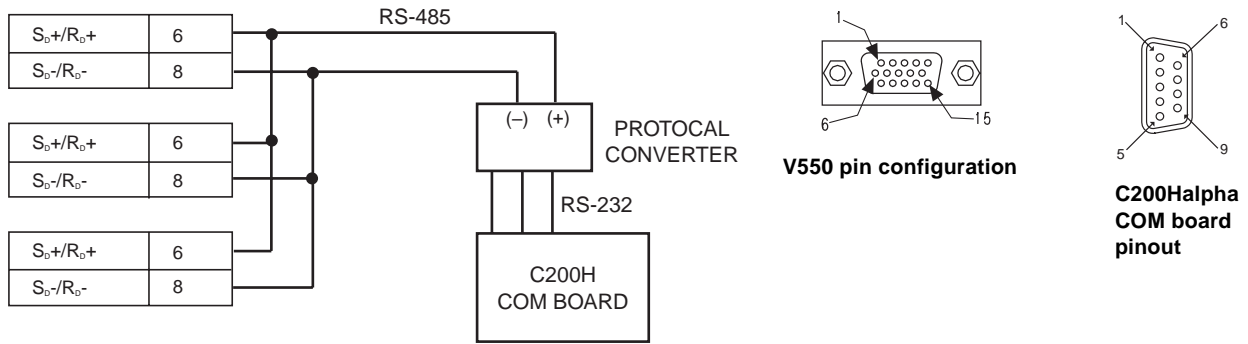

Note: The above connection is shown using the C200Hα PLC with protocol macro function. Contact Omron for the latest V550-A20 protocol macro.

**Dimensions**

Unit: mm (inch)

■ **READERS AND ACCESSORIES**

**V550-A20 Bar Code Reader**

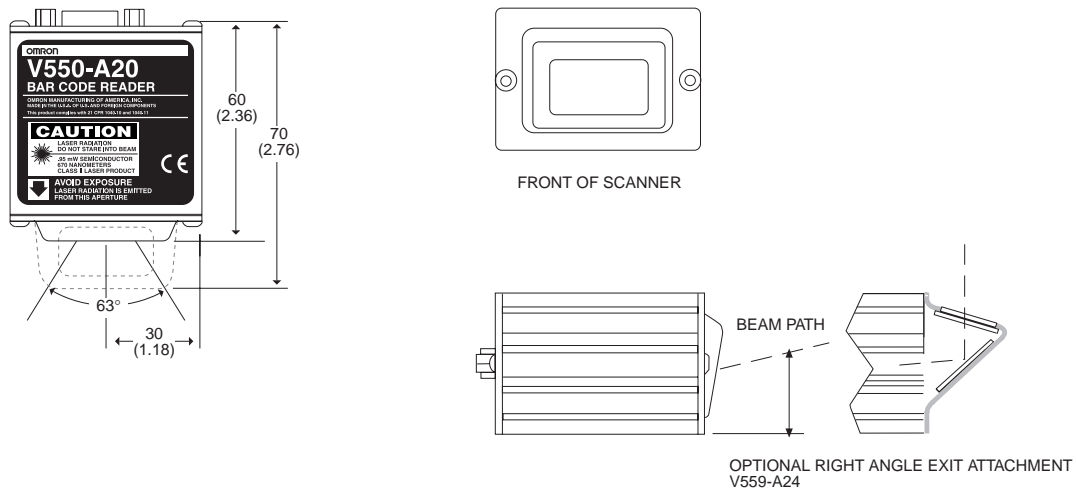

**S82S-0305 Power Supply**

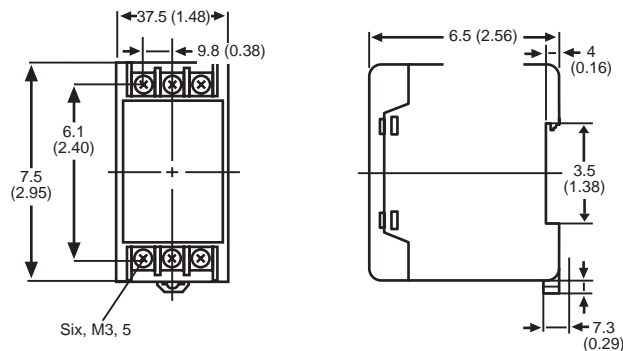

Unit: mm (inch)

**V559-A25C Programming Kit**

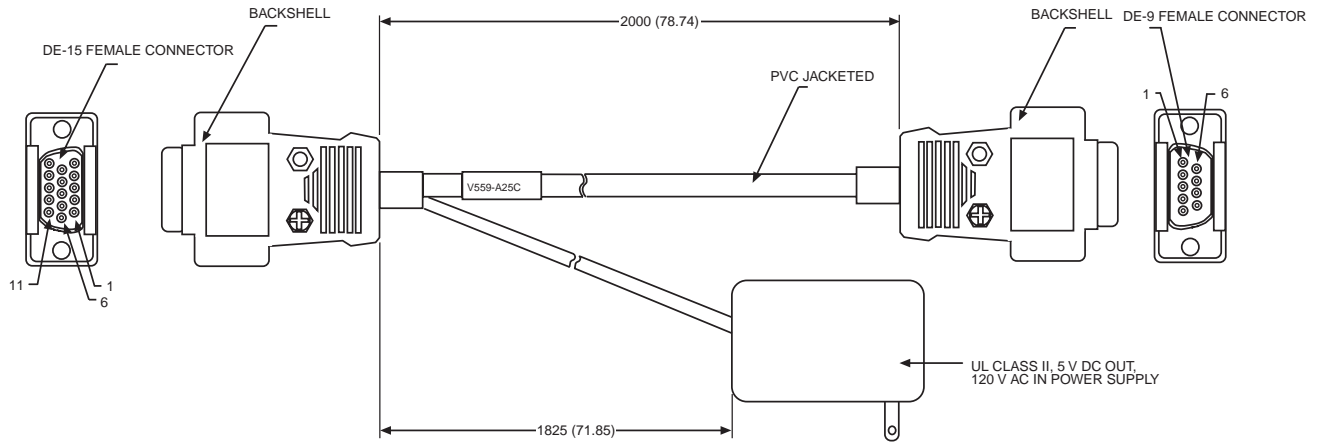

**V559-A32A-□M BCR to OMRON PLC RS-232 Port Cable**

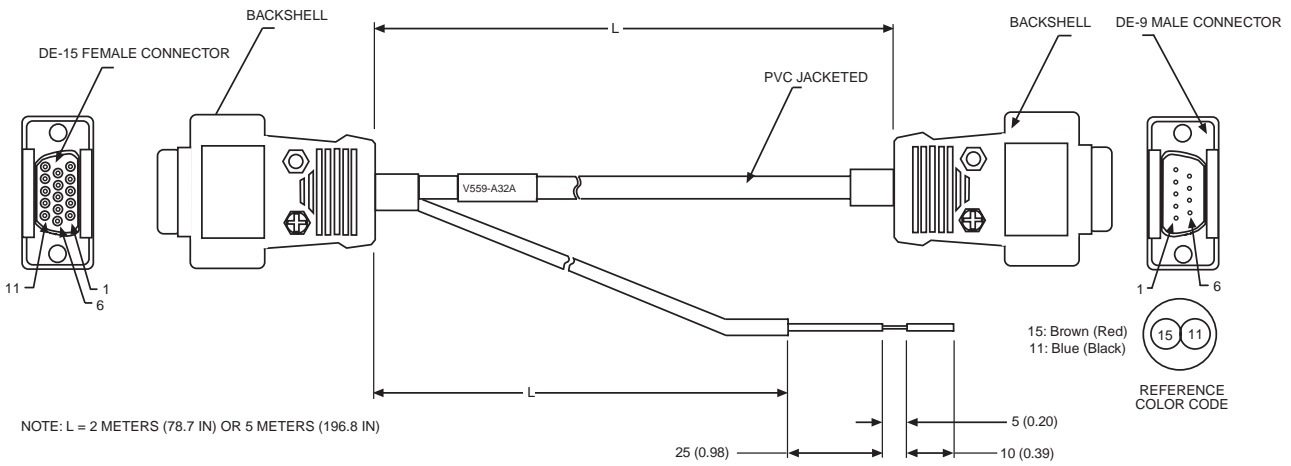

**V559-A32B Programming Cable**

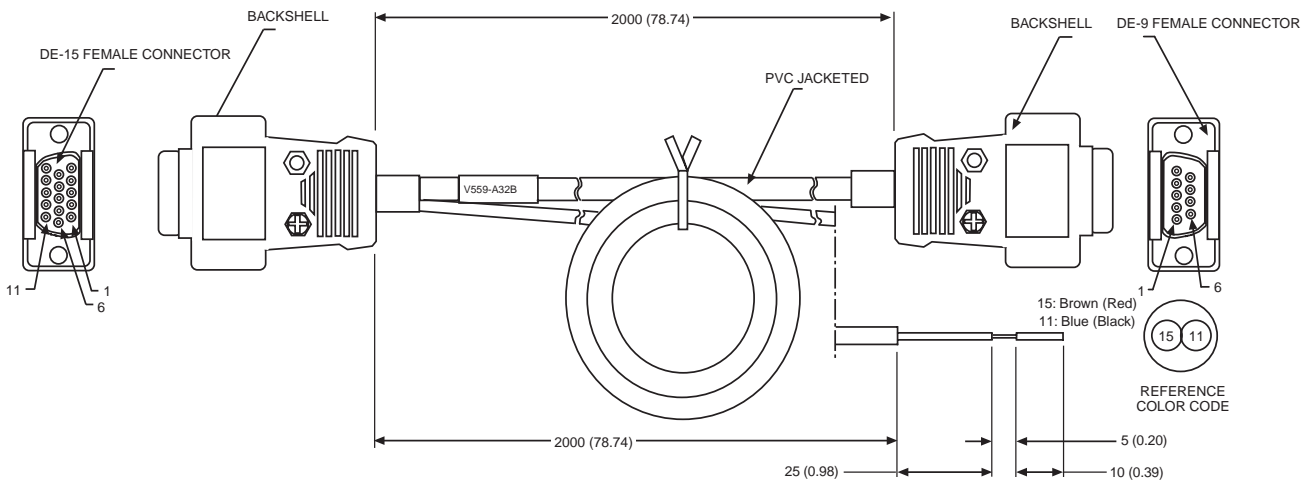

Unit: mm (inch)

■ MOUNTING BRACKETS

V559-A26F Mounting Clip

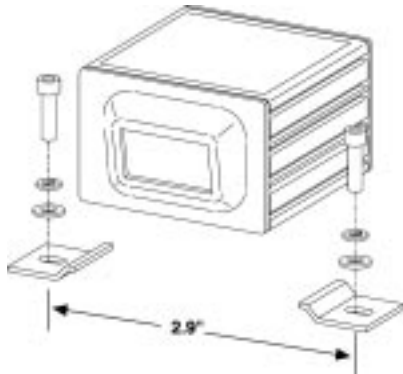
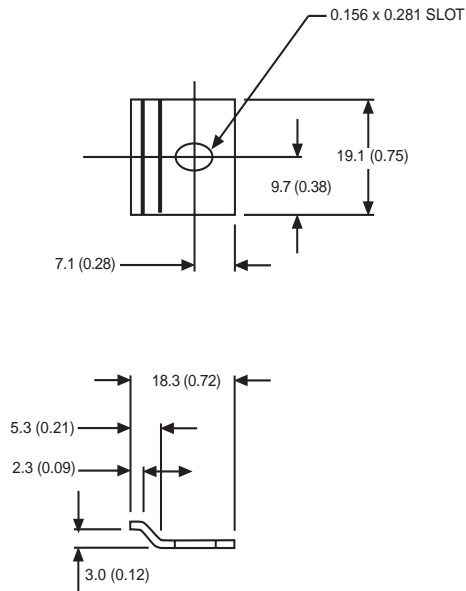

V559-A26A Mounting Plate

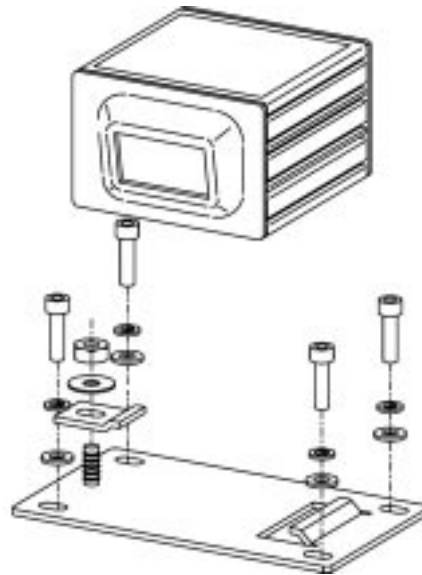
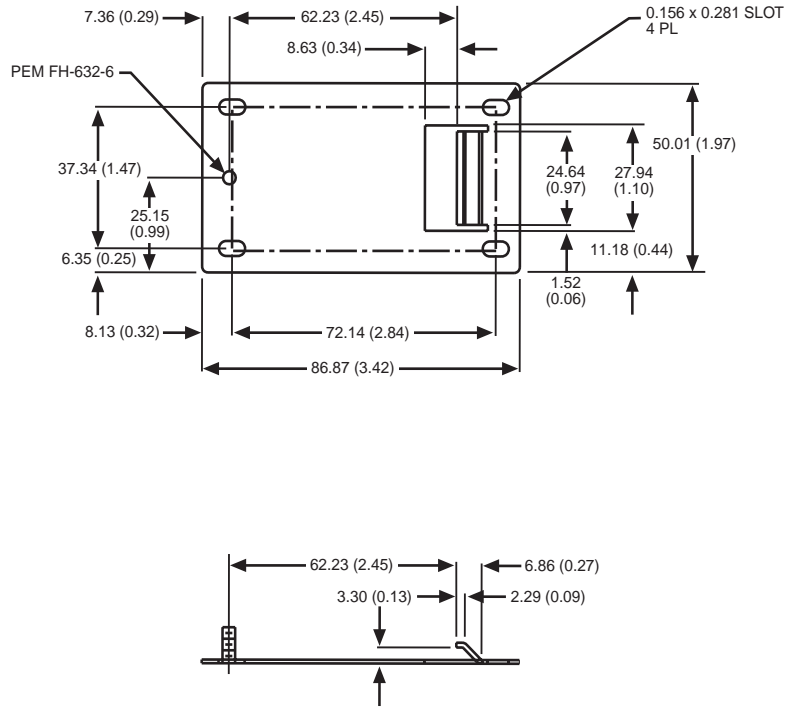

Unit: mm (inch)

**V559-A26D Picket Fence Mounting Bracket**

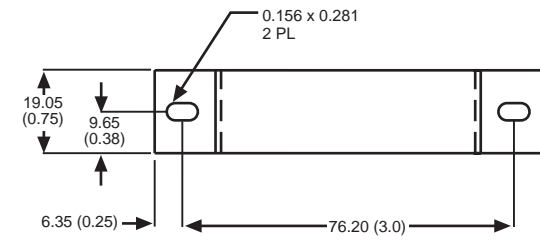

**V559-A26E Ladder Mounting Bracket**

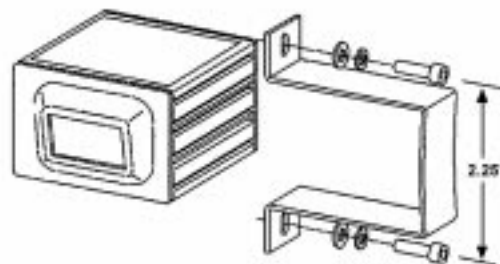
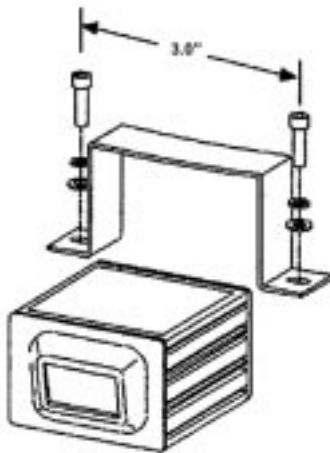
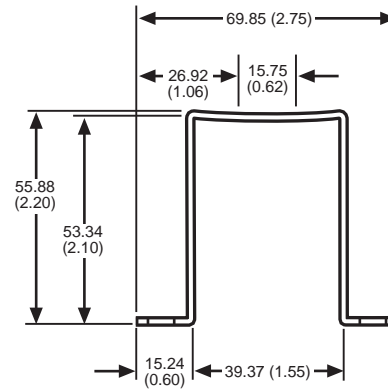
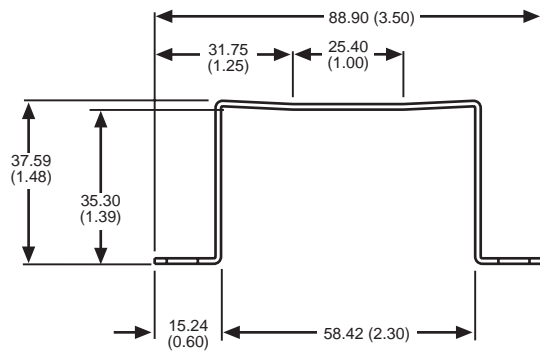
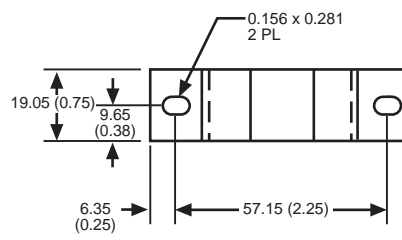

Unit: mm (inch)

**V559-A26B Cradle Mounting Bracket**

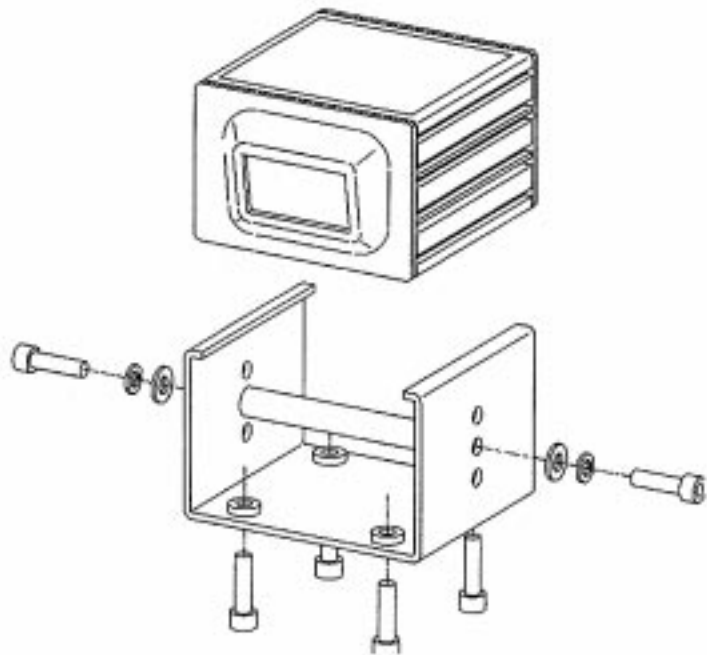
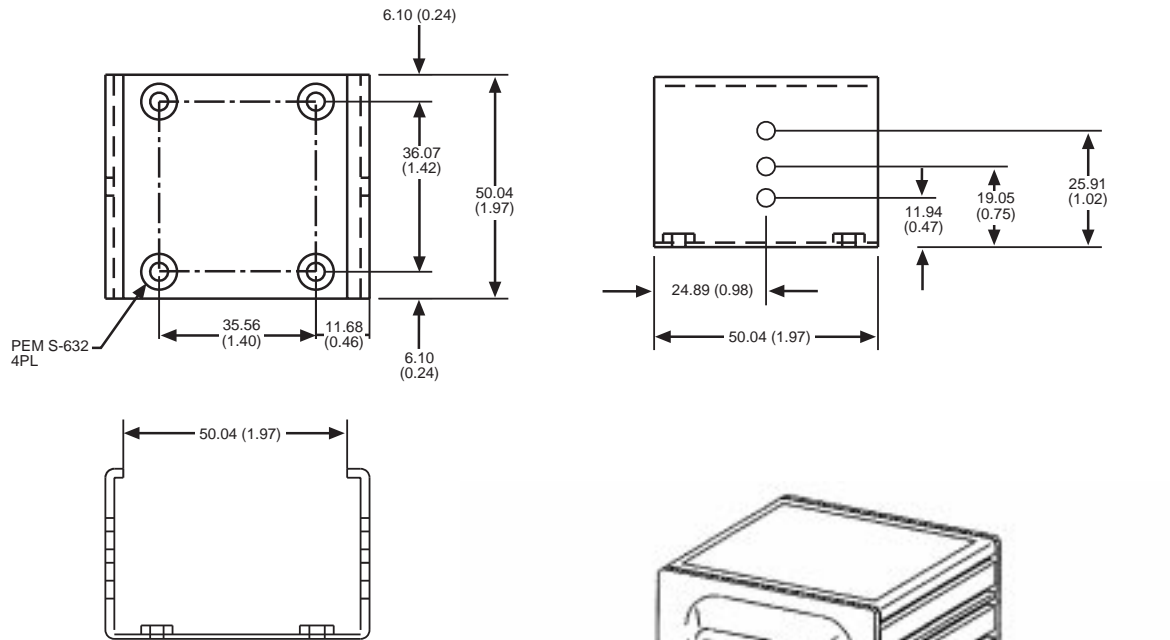

■ **BAR CODE SCANNING EXAMPLES**

Single Line Scan

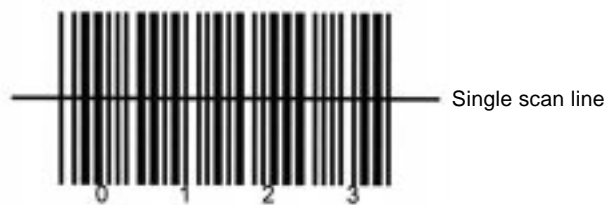

Raster Scan

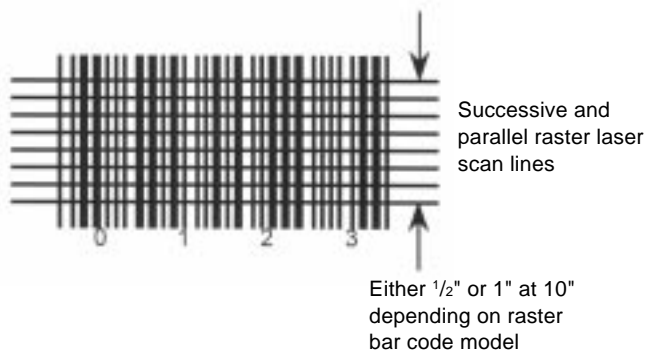

# Symbologies

## ■ BAR CODE SAMPLES / NARROW ELEMENT WIDTHS

- CODE-39 (also known as Code 3 of 9)



10 mil (12 digits)



15 mil (6 digits)

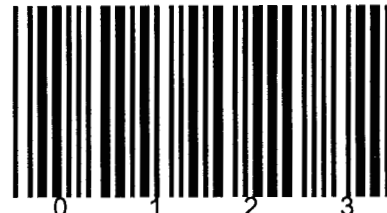

20 mil (4 digits)

- CODE-93



10 mil (8digits)



15 mil (6 digits)

- CODE-128



10 mil (6digits)



15 mil (6 digits)



20 mil (6 digits)

- UPC-A



13 mil

- UPC-E



13 mil

- EAN-8



15 mil

- EAN-13



15 mil

- Interleaved 2 of 5 (also known as "I 2 of 5")



15 mil (8 digits)



15 mil (10 digits)

- Straight 2 of 5



15 mil (6 digits)

- Codabar



10 mil (6 digits)



7.5 mil (15 digits)



10 mil (10 digits)

# Precautions

## ■ LASER BEAM SAFETY

"Low power" lasers are by definition incapable of causing eye injury within the duration of the blink, or aversion response (0.25 s) and must be visible (400 nm to 700 nm). Therefore, an ocular hazard can only exist if an individual overcomes his/her natural aversion to bright light and stares directly into the laser beam. There are two product requirements for these lasers: to have a CAUTION label and to have an indicator light to indicate laser emission.

The two operational safety rules are:

- Do not permit a person to stare at the laser from within the beam.
- Do not point the laser at a person's eye at close range.

Follow the instructions on this datasheet for the adjustment and mounting of the V550-A20.

Make sure that the laser beam will not be directly or indirectly reflected into human eyes. The safety distance is approximately 1 m for the V550-A20. If there is a possibility of laser beam reflection by any objects around the emitter at the time of adjustment, apply paint with a low light reflection ratio to the objects.

The sensor incorporates a laser emission warning light and a "scanning safeguard" feature which shuts off the laser power if the mirror wheel fails to rotate. This ensures that a stationary laser beam cannot emanate from the scan head.

FDA, IEC Laser class	I	Ila	II	IIIa	IIIb	IV
Remote interlock connector	N/A	N/A	N/A	N/A	R	R
Key Control	N/A	N/A	N/A	N/A	R	R
Emission indicator	N/A	N/A	R	R	R	R
Beam attenuator	N/A	N/A	N/A	R	R <sup>1</sup>	R <sup>1</sup>

Note: In the chart above: R = require; N/A = not applicable; R<sup>1</sup> = delay required between indication and emission.

## ■ LASER CONTROL REGULATIONS

The V550-A20 Bar Code Reader meets the standards required by the U.S. Food and Drug Administration (FDA). This reader also has been reported to the Center for Devices and Radiological Health (CDRH). Any service performed on this device should be done so as to not violate compliance with the *Code of Federal Regulations, Title 21, Part 1040, Section 10* (21 CFR 1040.10).

### Labels (FDA Regulations)

Laser radiation warning and information labels are located on the top side of the bar code reader.



## ■ INSTALLATION

Install the bar code reader in a location where the laser beam will not enter the operator's eyes directly or from reflection by a mirrored surface. Also, mount the operation indicator (LED) in a clearly visible location. Avoid interference from ambient light shining into BCR's window. Avoid excessive dust on window. Avoid scratching window. Avoid subjecting the bar code reader to heavy vibration.

## ■ MAINTENANCE AND REPAIR

**DANGER!**  
 Never disassemble the reader. Users expose themselves to the risk of laser radiation if they disassemble the device.

Do not attempt repairs or maintenance of the V550-A20. The V550-A20 contains no user serviceable parts. Refer all servicing to an authorized Omron representative.

DRX is a registered trademark of Accu-Sort Systems, Inc.

**NOTE: DIMENSIONS SHOWN ARE IN MILLIMETERS. To convert millimeters to inches, divide by 25.4.**

---

**OMRON****OMRON ELECTRONICS, INC.**

One East Commerce Drive  
Schaumburg, IL 60173

**1-800-55-OMRON****OMRON CANADA, INC.**

885 Milner Avenue  
Scarborough, Ontario M1B 5V8

**416-286-6465**