

SYSMAC
C200H-AD001/DA001
Analog I/O Units

OPERATION GUIDE

OMRON®

SYSMAC C200H-AD001/DA001 Analog I/O Units

Operation Guide

Revised February 2001

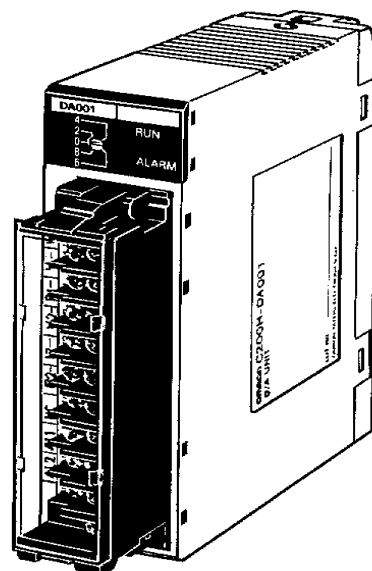
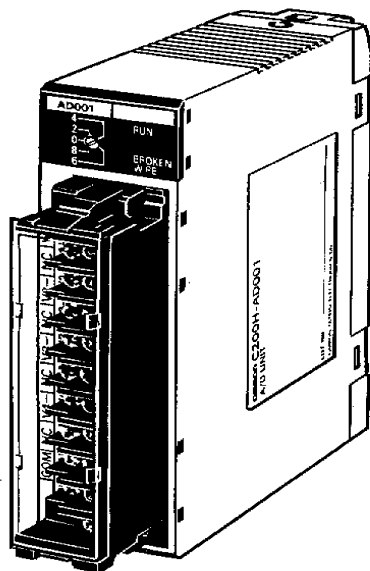

Terms and Conditions of Sale

- Offer: Acceptance.** These terms and conditions (these "Terms") are deemed part of all quotes, agreements, purchase orders, acknowledgments, price lists, catalogs, manuals, brochures and other documents, whether electronic or in writing, relating to the sale of products or services (collectively, the "Products") by Omron Electronics LLC and its subsidiary companies ("Omron"). Omron objects to any terms or conditions proposed in Buyer's purchase order or other documents which are inconsistent with, or in addition to, these Terms.
- Prices: Payment Terms.** All prices stated are current, subject to change without notice by Omron. Omron reserves the right to increase or decrease prices on any unshipped portions of outstanding orders. Payments for Products are due net 30 days unless otherwise stated in the invoice.
- Discounts.** Cash discounts, if any, will apply only on the net amount of invoices sent to Buyer after deducting transportation charges, taxes and duties, and will be allowed only if (i) the invoice is paid according to Omron's payment terms and (ii) Buyer has no past due amounts.
- Interest.** Omron, at its option, may charge Buyer 1-1/2% interest per month or the maximum legal rate, whichever is less, on any balance not paid within the stated terms.
- Orders.** Omron will accept no order less than \$200 net billing.
- Governmental Approvals.** Buyer shall be responsible for, and shall bear all costs involved in, obtaining any government approvals required for the importation or sale of the Products.
- Taxes.** All taxes, duties and other governmental charges (other than general real property and income taxes), including any interest or penalties thereon, imposed directly or indirectly on Omron or required to be collected directly or indirectly by Omron for the manufacture, production, sale, delivery, importation, consumption or use of the Products sold hereunder (including customs duties and sales, excise, use, turnover and license taxes) shall be charged to and remitted by Buyer to Omron.
- Financial.** If the financial position of Buyer at any time becomes unsatisfactory to Omron, Omron reserves the right to stop shipments or require satisfactory security or payment in advance. If Buyer fails to make payment or otherwise comply with these Terms or any related agreement, Omron may (without liability and in addition to other remedies) cancel any unshipped portion of Products sold hereunder and stop any Products in transit until Buyer pays all amounts, including amounts payable hereunder, whether or not then due, which are owing to it by Buyer. Buyer shall in any event remain liable for all unpaid accounts.
- Cancellation: Etc.** Orders are not subject to rescheduling or cancellation unless Buyer indemnifies Omron against all related costs or expenses.
- Force Majeure.** Omron shall not be liable for any delay or failure in delivery resulting from causes beyond its control, including earthquakes, fires, floods, strikes or other labor disputes, shortage of labor or materials, accidents to machinery, acts of sabotage, riots, delay in or lack of transportation or the requirements of any government authority.
- Shipping: Delivery.** Unless otherwise expressly agreed in writing by Omron:
 - Shipments shall be by a carrier selected by Omron; Omron will not drop ship except in "break down" situations.
 - Such carrier shall act as the agent of Buyer and delivery to such carrier shall constitute delivery to Buyer;
 - All sales and shipments of Products shall be FOB shipping point (unless otherwise stated in writing by Omron), at which point title and risk of loss shall pass from Omron to Buyer; provided that Omron shall retain a security interest in the Products until the full purchase price is paid;
 - Delivery and shipping dates are estimates only; and
 - Omron will package Products as it deems proper for protection against normal handling and extra charges apply to special conditions.
- Claims.** Any claim by Buyer against Omron for shortage or damage to the Products occurring before delivery to the carrier must be presented in writing to Omron within 30 days of receipt of shipment and include the original transportation bill signed by the carrier noting that the carrier received the Products from Omron in the condition claimed.
- Warranties.** (a) **Exclusive Warranty.** Omron's exclusive warranty is that the Products will be free from defects in materials and workmanship for a period of twelve months from the date of sale by Omron (or such other period expressed in writing by Omron). Omron disclaims all other warranties, express or implied. (b) **Limitations.** OMRON MAKES NO WARRANTY OR REPRESENTATION, EXPRESS OR IMPLIED, ABOUT NON-INFRINGEMENT, MERCHANTABILITY OR FITNESS FOR A PARTICULAR PURPOSE OF THE PRODUCTS. BUYER ACKNOWLEDGES THAT IT ALONE HAS DETERMINED THAT THE PRODUCTS WILL SUITABLY MEET THE REQUIREMENTS OF THEIR INTENDED USE. Omron further disclaims all warranties and responsibility of any type for claims or expenses based on infringement by the Products or otherwise of any intellectual property right. (c) **Buyer Remedy.** Omron's sole obligation hereunder shall be, at Omron's election, to (i) replace (in the form originally shipped with Buyer responsible for labor charges for removal or replacement thereof) the non-complying Product, (ii) repair the non-complying Product, or (iii) repay or credit Buyer an amount equal to the purchase price of the non-complying Product; provided that in no event shall Omron be responsible for warranty, repair, indemnity or any other claims or expenses regarding the Products unless Omron's analysis confirms that the Products were properly handled, stored, installed and maintained and not subject to contamination, abuse, misuse or inappropriate modification. Return of any Products by Buyer must be approved in writing by Omron before shipment. Omron Companies shall not be liable for the suitability or unsuitability or the results from the use of Products in combination with any electrical or electronic components, circuits, system assemblies or any other materials or substances or environments. Any advice, recommendations or information given orally or in writing, are not to be construed as an amendment or addition to the above warranty. See <http://oeweb.omron.com> or contact your Omron representative for published information.
- Limitation on Liability: Etc.** OMRON COMPANIES SHALL NOT BE LIABLE FOR SPECIAL, INDIRECT, INCIDENTAL, OR CONSEQUENTIAL DAMAGES, LOSS OF PROFITS OR PRODUCTION OR COMMERCIAL LOSS IN ANY WAY CONNECTED WITH THE PRODUCTS, WHETHER SUCH CLAIM IS BASED IN CONTRACT, WARRANTY, NEGLIGENCE OR STRICT LIABILITY. Further, in no event shall liability of Omron Companies exceed the individual price of the Product on which liability is asserted.
- Indemnities.** Buyer shall indemnify and hold harmless Omron Companies and their employees from and against all liabilities, losses, claims, costs and expenses (including attorney's fees and expenses) related to any claim, investigation, litigation or proceeding (whether or not Omron is a party) which arises or is alleged to arise from Buyer's acts or omissions under these Terms or in any way with respect to the Products. Without limiting the foregoing, Buyer (at its own expense) shall indemnify and hold harmless Omron and defend or settle any action brought against such Companies to the extent based on a claim that any Product made to Buyer specifications infringed intellectual property rights of another party.
- Property: Confidentiality.** Any intellectual property in the Products is the exclusive property of Omron Companies and Buyer shall not attempt to duplicate it in any way without the written permission of Omron. Notwithstanding any charges to Buyer for engineering or tooling, all engineering and tooling shall remain the exclusive property of Omron. All information and materials supplied by Omron to Buyer relating to the Products are confidential and proprietary, and Buyer shall limit distribution thereof to its trusted employees and strictly prevent disclosure to any third party.
- Export Controls.** Buyer shall comply with all applicable laws, regulations and licenses regarding (i) export of products or information; (iii) sale of products to "forbidden" or other proscribed persons; and (ii) disclosure to non-citizens of regulated technology or information.
- Miscellaneous.** (a) **Waiver.** No failure or delay by Omron in exercising any right and no course of dealing between Buyer and Omron shall operate as a waiver of rights by Omron. (b) **Assignment.** Buyer may not assign its rights hereunder without Omron's written consent. (c) **Law.** These Terms are governed by the law of the jurisdiction of the home office of the Omron company from which Buyer is purchasing the Products (without regard to conflict of law principles). (d) **Amendment.** These Terms constitute the entire agreement between Buyer and Omron relating to the Products, and no provision may be changed or waived unless in writing signed by the parties. (e) **Severability.** If any provision hereof is rendered ineffective or invalid, such provision shall not invalidate any other provision. (f) **Setoff.** Buyer shall have no right to set off any amounts against the amount owing in respect of this invoice. (g) **Definitions.** As used herein, "including" means "including without limitation"; and "Omron Companies" (or similar words) mean Omron Corporation and any direct or indirect subsidiary or affiliate thereof.

Certain Precautions on Specifications and Use

- Suitability of Use.** Omron Companies shall not be responsible for conformity with any standards, codes or regulations which apply to the combination of the Product in the Buyer's application or use of the Product. At Buyer's request, Omron will provide applicable third party certification documents identifying ratings and limitations of use which apply to the Product. This information by itself is not sufficient for a complete determination of the suitability of the Product in combination with the end product, machine, system, or other application or use. Buyer shall be solely responsible for determining appropriateness of the particular Product with respect to Buyer's application, product or system. Buyer shall take application responsibility in all cases but the following is a non-exhaustive list of applications for which particular attention must be given:
 - Outdoor use, uses involving potential chemical contamination or electrical interference, or conditions or uses not described in this document.
 - Use in consumer products or any use in significant quantities.
 - Energy control systems, combustion systems, railroad systems, aviation systems, medical equipment, amusement machines, vehicles, safety equipment, and installations subject to separate industry or government regulations.
 - Systems, machines and equipment that could present a risk to life or property. Please know and observe all prohibitions of use applicable to this Product.

NEVER USE THE PRODUCT FOR AN APPLICATION INVOLVING SERIOUS RISK TO LIFE OR PROPERTY OR IN LARGE QUANTITIES WITHOUT ENSURING THAT THE SYSTEM AS A WHOLE HAS BEEN DESIGNED TO ADDRESS THE RISKS, AND THAT THE OMRON'S PRODUCT IS PROPERLY RATED AND INSTALLED FOR THE INTENDED USE WITHIN THE OVERALL EQUIPMENT OR SYSTEM.
- Programmable Products.** Omron Companies shall not be responsible for the user's programming of a programmable Product, or any consequence thereof.
- Performance Data.** Data presented in Omron Company websites, catalogs and other materials is provided as a guide for the user in determining suitability and does not constitute a warranty. It may represent the result of Omron's test conditions, and the user must correlate it to actual application requirements. Actual performance is subject to the Omron's Warranty and Limitations of Liability.
- Change in Specifications.** Product specifications and accessories may be changed at any time based on improvements and other reasons. It is our practice to change part numbers when published ratings or features are changed, or when significant construction changes are made. However, some specifications of the Product may be changed without any notice. When in doubt, special part numbers may be assigned to fix or establish key specifications for your application. Please consult with your Omron's representative at any time to confirm actual specifications of purchased Product.
- Errors and Omissions.** Information presented by Omron Companies has been checked and is believed to be accurate; however, no responsibility is assumed for clerical, typographical or proofreading errors or omissions.

Notice:

OMRON products are manufactured for use according to proper procedures by a qualified operator and only for the purposes described in this manual.

The following conventions are used to indicate and classify precautions in this manual. Always heed the information provided with them. Failure to heed precautions can result in injury to people or damage to property.

 **DANGER** Indicates an imminently hazardous situation which, if not avoided, will result in death or serious injury.

 **WARNING** Indicates a potentially hazardous situation which, if not avoided, could result in death or serious injury.

 **Caution** Indicates a potentially hazardous situation which, if not avoided, may result in minor or moderate injury, or property damage.

OMRON Product References

All OMRON products are capitalized in this manual. The word “Unit” is also capitalized when it refers to an OMRON product, regardless of whether or not it appears in the proper name of the product.

The abbreviation “Ch,” which appears in some displays and on some OMRON products, often means “word” and is abbreviated “Wd” in documentation in this sense.

The abbreviation “PC” means Programmable Controller and is not used as an abbreviation for anything else.

Visual Aids

The following headings appear in the left column of the manual to help you locate different types of information.

Note Indicates information of particular interest for efficient and convenient operation of the product.

Reference Indicates supplementary information on related topics that may be of interest to the user.

1, 2, 3... 1. Indicates lists of one sort or another, such as procedures, checklists, etc.

© OMRON, 1990

All rights reserved. No part of this publication may be reproduced, stored in a retrieval system, or transmitted, in any form, or by any means, mechanical, electronic, photocopying, recording, or otherwise, without the prior written permission of OMRON.

No patent liability is assumed with respect to the use of the information contained herein. Moreover, because OMRON is constantly striving to improve its high-quality products, the information contained in this manual is subject to change without notice. Every precaution has been taken in the preparation of this manual. Nevertheless, OMRON assumes no responsibility for errors or omissions. Neither is any liability assumed for damages resulting from the use of the information contained in this publication.

TABLE OF CONTENTS

PRECAUTIONS	xi
1 Intended Audience	xii
2 General Precautions	xii
3 Safety Precautions	xii
4 Operating Environment Precautions	xiii
5 Application Precautions	xiii
SECTION 1	
System Design	1
1-1 Introduction	2
1-2 Safety Precautions	2
1-3 Basic Configuration	3
1-4 Example Configurations	4
1-5 System Considerations	5
SECTION 2	
C200H-AD001 Analog Input Unit	7
2-1 Before Operation	8
2-2 Bit and DM Area Allocations	15
2-3 Functions and Programming	18
2-4 Troubleshooting	26
SECTION 3	
C200H-DA001 Analog Output Units	29
3-1 Before Operation	30
3-2 Bit and DM Allocations	36
3-3 Functions and Programming	38
3-4 Troubleshooting	45
Appendices	
A Standard Models	47
B Specifications	49
C Data Memory Coding Sheets	53
Index	55
Revision History	57

About this Manual:

This guide describes the installation and operation of the C200H-AD001 Analog Input Unit and the C200H-DA001 Analog Output Unit and includes the sections described below.

The C200H-AD001 Analog Input Unit and the C200H-DA001 Analog Output Unit are analog-digital and digital-analog converters designed to work with the C200H or C200HS PC.

The C200H-AD001 can convert up to four analog inputs to digital (12-bit binary) form. The operator can select from three input ranges: 1 to 5 V and 4 to 20 mA (simultaneous use of voltage and current inputs possible), or 0 to 10 V (voltage inputs only). Useful functions, such as scaling, mean value, peak value, and square root, are built-in.

The C200H-DA001 can convert two digital (12-bit binary) signals to analog outputs. The operator can select from three output ranges: 1 to 5 V, 4 to 20 mA, or 0 to 10 V. Built-in functions include output limit, output limit alarm, and pulse output.

Please read this manual carefully and be sure you understand the information provided before attempting to install and operate the C200H-AD001 or the C200H-DA001

Section 1 describes the types of applications in which Analog I/O Units are used.

Section 2 describes the installation and operation of the C200H-AD001 Analog Input Unit, from installation and wiring through programming and operation.

Section 3 describes the installation and operation of the C200H-DA001 Analog Output Unit, from installation and wiring through programming and operation.



WARNING Failure to read and understand the information provided in this manual may result in personal injury or death, damage to the product, or product failure. Please read each section in its entirety and be sure you understand the information provided in the section and related sections before attempting any of the procedures or operations given.

PRECAUTIONS

This section provides general precautions for using the Programmable Controller (PC) and Analog I/O Units.

The information contained in this section is important for the safe and reliable application of the Analog I/O Units. You must read this section and understand the information contained before attempting to set up or operate a PC system and Analog I/O Units.

1 Intended Audience	xii
2 General Precautions	xii
3 Safety Precautions	xii
4 Operating Environment Precautions	xiii
5 Application Precautions	xiii

1 Intended Audience

This manual is intended for the following personnel, who must also have knowledge of electrical systems (an electrical engineer or the equivalent).

- Personnel in charge of installing FA systems
- Personnel in charge of designing FA systems
- Personnel in charge of managing FA systems and facilities

2 General Precautions

The user must operate the product according to the performance specifications described in the operation manuals.



Before using the product under conditions which are not described in the manual or applying the product to nuclear control systems, railroad systems, aviation systems, vehicles, combustion systems, medical equipment, amusement machines, safety equipment, and other systems, machines, and equipment that may have a serious influence on lives and property if used improperly, consult your OMRON representative.

Make sure that the ratings and performance characteristics of the product are sufficient for the systems, machines, and equipment, and be sure to provide the systems, machines, and equipment with double safety mechanisms.



This manual provides information for programming and operating OMRON Analog I/O Units. Be sure to read this manual before attempting to use the software and keep this manual close at hand for reference during operation.

-  **WARNING** It is extremely important that a PC and all PC Units be used for the specified purpose and under the specified conditions, especially in applications that can directly or indirectly affect human life. You must consult with your OMRON representative before applying a PC System to the above-mentioned applications.

3 Safety Precautions



-  **WARNING** Do not attempt to take any Unit apart while power is being supplied. Doing so may result in electric shock.
-  **WARNING** Do not touch any of the terminals or terminal blocks while power is being supplied. Doing so may result in electric shock.

4 Operating Environment Precautions

-  **Caution** Do not operate the control system in the following places:
- Locations subject to direct sunlight.
 - Locations subject to temperatures or humidity outside the range specified in the specifications.
 - Locations subject to condensation as the result of severe changes in temperature.
 - Locations subject to corrosive or flammable gases.
 - Locations subject to dust (especially iron dust) or salts.
 - Locations subject to exposure to water, oil, or chemicals.
 - Locations subject to shock or vibration.
-  **Caution** Take appropriate and sufficient countermeasures when installing systems in the following locations:
- Locations subject to static electricity or other forms of noise.
 - Locations subject to strong electromagnetic fields.
 - Locations subject to possible exposure to radioactivity.
 - Locations close to power supplies.
-  **Caution** The operating environment of the PC System can have a large effect on the longevity and reliability of the system. Improper operating environments can lead to malfunction, failure, and other unforeseeable problems with the PC System. Be sure that the operating environment is within the specified conditions at installation and remains within the specified conditions during the life of the system.

5 Application Precautions

Observe the following precautions when using the PC.

-  **WARNING** Always heed these precautions. Failure to abide by the following precautions could lead to serious or possibly fatal injury.
- Always connect to a ground of 100 Ω or less when installing the Units. Not connecting to a ground of 100 Ω or less may result in electric shock.
 - Always turn off the power supply to the PC before attempting any of the following. Not turning off the power supply may result in malfunction or electric shock.
 - Mounting or dismounting I/O Units, CPU Units, Memory Cassettes, or any other Units.
 - Assembling the Units.
 - Setting DIP switch or rotary switches.
 - Connecting or wiring the cables.
 - Connecting or disconnecting the connectors.
-  **Caution** Failure to abide by the following precautions could lead to faulty operation of the PC or the system, or could damage the PC or PC Units. Always heed these precautions.
- Fail-safe measures must be taken by the customer to ensure safety in the event of incorrect, missing, or abnormal signals caused by broken signal lines, momentary power interruptions, or other causes.

- Interlock circuits, limit circuits, and similar safety measures in external circuits (i.e., not in the Programmable Controller) must be provided by the customer.
- Always use the power supply voltage specified in this manual. An incorrect voltage may result in malfunction or burning.
- Take appropriate measures to ensure that the specified power with the rated voltage and frequency is supplied. Be particularly careful in places where the power supply is unstable. An incorrect power supply may result in malfunction.
- Do not apply voltages to the Input Units in excess of the rated input voltage. Excess voltages may result in burning.
- Do not apply voltages or connect loads to the Output Units in excess of the maximum switching capacity. Excess voltage or loads may result in burning.
- Install external breakers and take other safety measures against short-circuiting in external wiring. Insufficient safety measures against short-circuiting may result in burning.
- Disconnect the functional ground terminal when performing withstand voltage tests. Not disconnecting the functional ground terminal may result in burning.
- Do not attempt to disassemble, repair, or modify any Units.
- Be sure that all the mounting screws, terminal screws, and cable connector screws are tightened to the torque specified in the relevant manuals. Incorrect tightening torque may result in malfunction.
- Leave the label attached to the Unit when wiring. Removing the label may result in malfunction if foreign matter such as wire cuttings enter the Unit.
- Remove the label after the completion of wiring to ensure proper heat dissipation. Leaving the label attached may result in malfunction.
- Use crimp terminals for wiring. Do not connect bare stranded wires directly to terminals. Connection of bare stranded wires may result in burning.
- Double-check all the wiring before turning on the power supply. Incorrect wiring may result in burning.
- Wire all connections correctly.
- Mount the Unit only after checking the terminal block completely.
- Be sure that the terminal blocks, Memory Units, expansion cables, and other items with locking devices are properly locked into place. Improper locking may result in malfunction.
- Check the user program for proper execution before actually running it on the Unit. Not checking the program may result in an unexpected operation.
- Confirm that no adverse effect will occur in the system before attempting any of the following. Not doing so may result in an unexpected operation.
 - Changing the operating mode of the PC.
 - Force-setting/force-resetting any bit in memory.
 - Changing the present value of any word or any set value in memory.
- Resume operation only after transferring to the new CPU Unit the contents of the DM Area, HR Area, and other data required for resuming operation. Not doing so may result in an unexpected operation.
- Do not pull on the cables or bend the cables beyond their natural limit. Doing either of these may break the cables.
- Do not place objects on top of the cables or other wiring lines. Doing so may break the cables.
- Before touching the Unit, be sure to first touch a grounded metallic object in order to discharge any static built-up. Not doing so may result in malfunction or damage.
- Install the Units properly as specified in the operation manuals. Improper installation of the Units may result in malfunction.

SECTION 1

System Design

This section describes the basic uses of Analog I/O Units in a Control System and illustrates the type of applications in which they might be found.

1-1	Introduction	2
1-2	Safety Precautions	2
1-3	Basic Configuration	3
1-4	Example Configurations	4
1-5	System Considerations	5

1-1 Introduction

The C200H-AD001 Analog Input Unit is used to convert the output of analog field devices, usually sensors, to a digital form (12-bit binary) that the PC can read. The C200H-DA001 Analog Output Unit converts the digital output of the PC to analog signals which drive analog field devices.

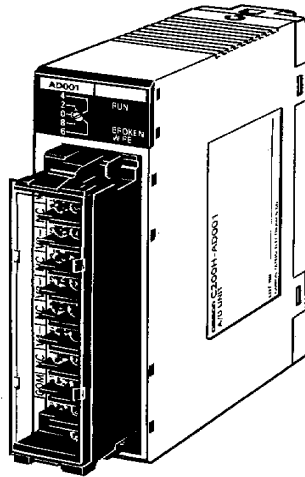

C200H-AD001
Analog Input Unit

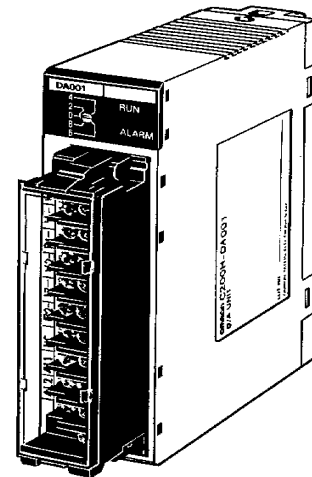

C200H-DA001
Analog Output Unit

1-2 Safety Precautions

- Be sure that you have read this manual carefully and have understood the explanations before attempting any of the procedures described herein. OMRON accepts no responsibility for any damage or injury that may result from carrying out any operation that is not covered in this manual.
- Be sure to turn off the power supply to the PC before carrying out any of the following operations:
 - a) Mounting or removing a Unit.
 - b) Setting switches.
 - c) Mounting or removing a Terminal Block or connectors.
 - d) Wiring the System or Units.
- Use twisted-pair cables and keep high-voltage lines and power lines in separate ducts to reduce the risk of malfunctions due to electrical noise.
- Before turning on the power supply, check to be sure that the switch settings and wiring are correct.
- Check to be sure that the user program operates correctly.

1-3 Basic Configuration

This diagram shows some of the possible field devices for the Analog I/O Units. Any I/O device can be used as long as voltage/current requirements fall within the specified ranges.

The I/O device connected to the Analog I/O Unit will often serve as an interface for another device. For example, a preamplifier may amplify the output of a pressure gauge to the level required for the Analog Input Unit and a regulator may interface a heating system to control temperature.

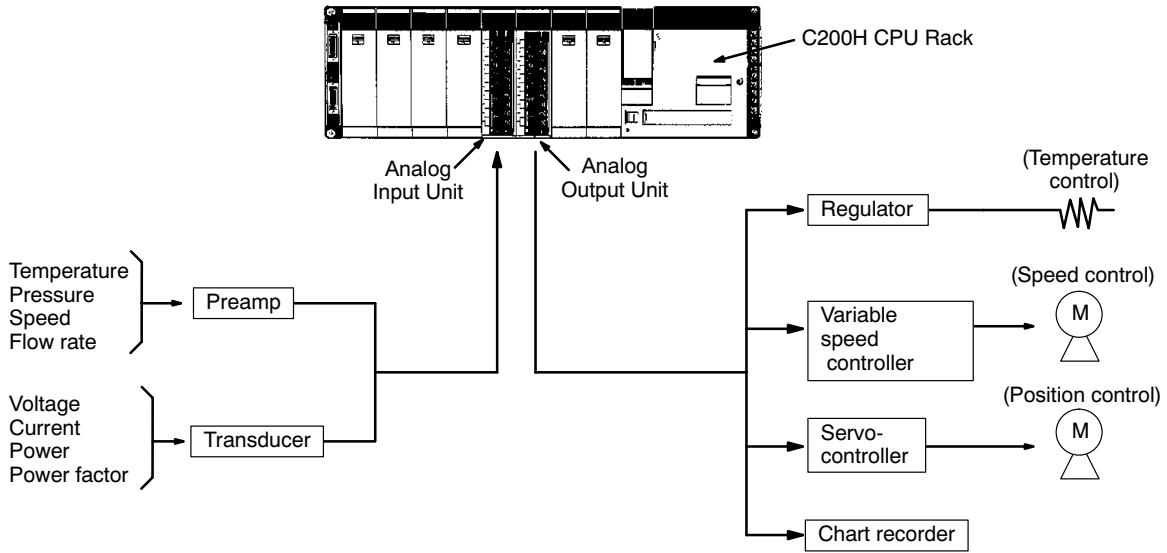

1-4 Example Configurations

Below are two examples of how Analog I/O Units can be used in control systems. The first diagram shows a temperature regulating system and the second shows a servomotor positioning system.

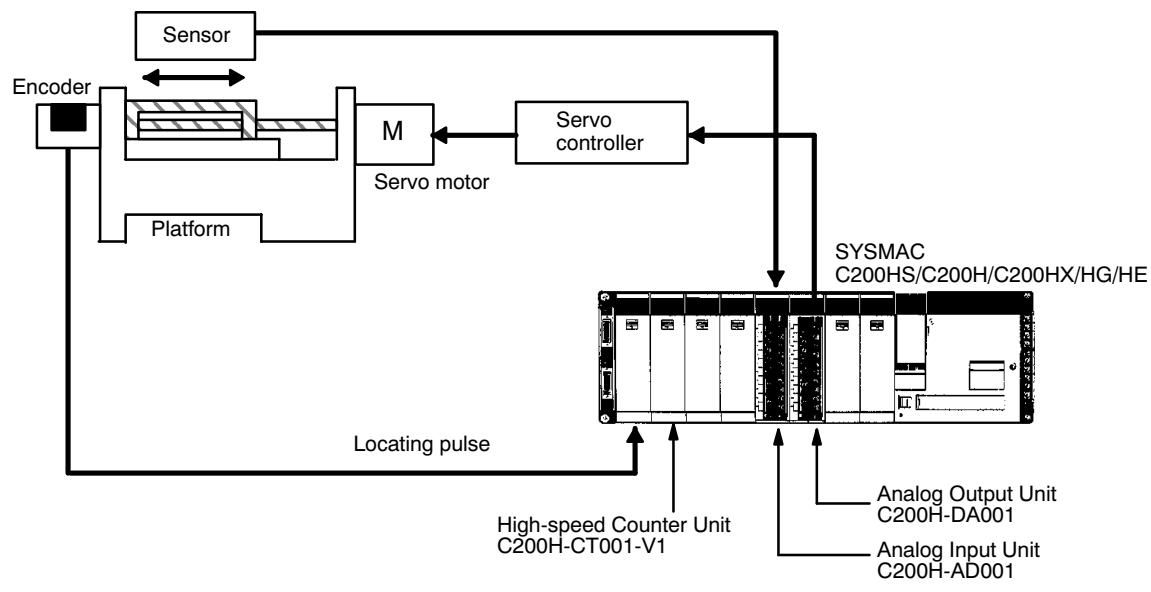
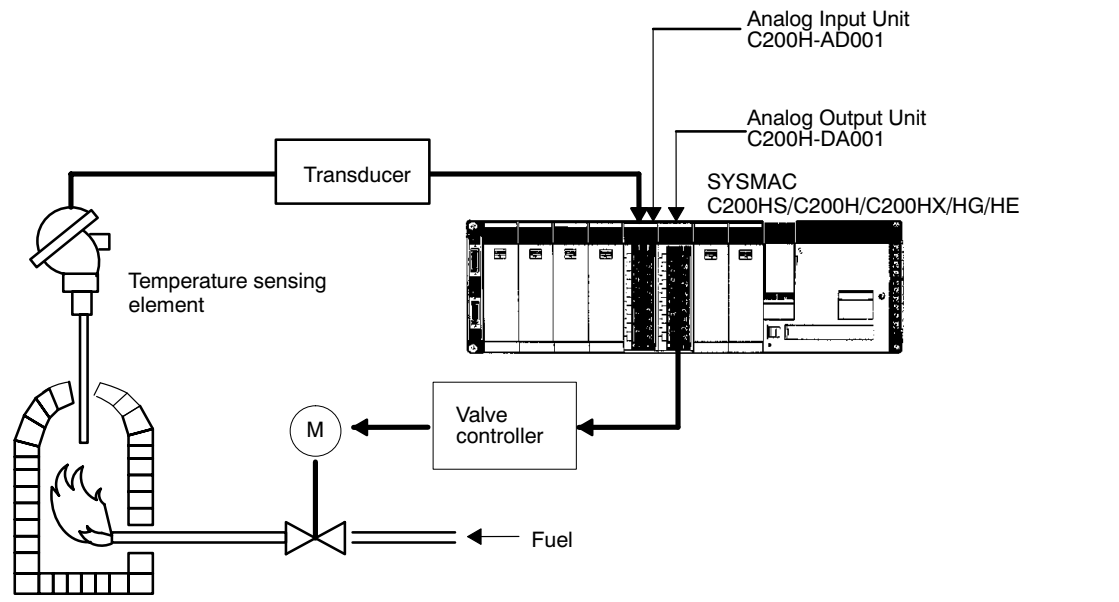

1-5 System Considerations

Number of Units

C200HS/C200H/C200HX/HG/HE Analog I/O Units are classified as Special I/O Units. A maximum total of ten Special I/O Units (including PC Link Units) can be mounted to the CPU Rack, Expansion I/O Racks, and Slave Racks of a single PC. A single C200H-NC211 Position Control Unit counts as two Units.

The Units that belong to the various Special I/O Unit groups are shown in the following table. Their usage is limited according to the maximum current provided for the Rack and the amount of current consumed by each Unit. For details, refer to the *C200HS/C200H Installation Guide*.

Slave Racks

Certain limitations apply to the number of Special I/O Units that can be mounted on Slave Racks. The following table shows the maximum number of Group A, B, C, and D Special I/O Units that can be mounted on a single Slave Rack when only Units of that group are used.

A	B	C	D
High-speed Counters Position Control Units (NC111/112) ASCII Units Analog I/O Units ID Sensor Units Fuzzy Logic Units	Multipoint I/O Units Temperature Control Units PID Control Units Cam Positioner Units	Temperature Sensor Units Voice Units	Position Control Units (NC211)
4 Units	---	---	---
---	8 Units	---	---
---	---	6 Units	---
---	---	---	2 Units

If Units from any of the four groups are to be combined, then both of the following two equations must be satisfied.

$$3A + B + 2C + 6D \leq 12$$

$$A + B + C + D \leq 8$$

Units can be mounted on other Racks as well, until the maximum total of ten Units has been reached. Remember, though, that a single C200H-NC211 Position Control Unit counts as two Units. PC Link Units must also be counted among the total of ten Units.

System Configuration Considerations

C200HS/C200H Special I/O Units are allocated IR area words according to the unit number switch settings on their front panels. They do not use the words of the slots in which they are mounted. For details regarding data area allocations, refer to 2-2 and 3-2 *IR and DM Bit Allocations*.

With the C200H, do not mount an Analog I/O Unit in the two slots adjacent to the CPU. Doing so would block peripheral devices such as the Programming Console from being connected.

Special I/O Units cannot be used on a C200H Remote I/O Slave Rack if the Slave Rack is connected to different model PC (i.e., C500, C1000H, or C2000H).

Precautions

Be sure to turn off the power supply to the PC before installing or disconnecting Units or connecting lines.

To reduce the risk of malfunctioning due to electrical noise, wire input and output lines in separate ducts from high-voltage and power lines.

For further wiring precautions, refer to the respective sections on wiring for Analog Input Units and Analog Output Units.

SECTION 2

C200H-AD001 Analog Input Unit

This section provides the information required to install and operate a C200H-AD001 Analog Input Unit.

2-1	Before Operation	8
2-1-1	Nomenclature and Functions	8
2-1-2	Switch Settings	10
2-1-3	Wiring	11
2-2	Bit and DM Area Allocations	15
2-3	Functions and Programming	18
2-3-1	Input Signal Range Setting	19
2-3-2	Square Root	19
2-3-3	Scaling	20
2-3-4	Mean Value	21
2-3-5	Peak Value	22
2-3-6	Input Disconnection Detection	23
2-3-7	Data Setting Example and Programming Concepts	23
2-4	Troubleshooting	26

2-1 Before Operation

2-1-1 Nomenclature and Functions

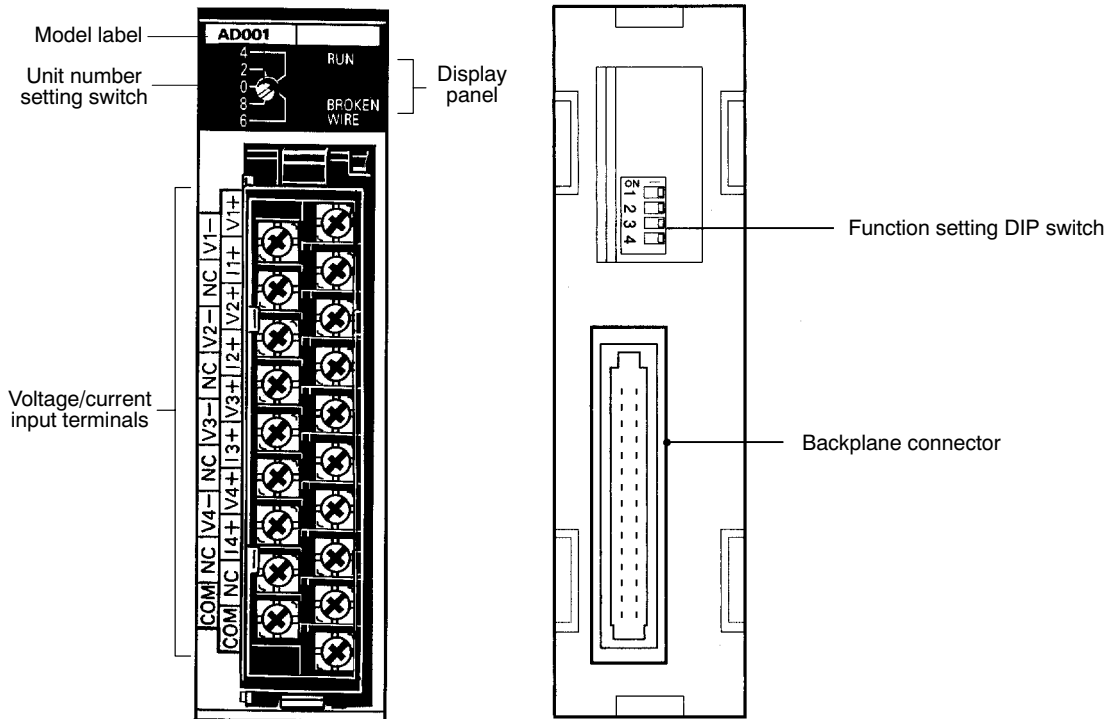

Indicators

Indicator	Color	Function
RUN	Green	Lit when the Analog Input Unit is operating correctly. If operation is not normal, this indicator turns OFF and Unit operation is stopped.
BROKEN WIRE	Red	Lit when an input signal wire is disconnected. This indicator operates only when the input range is set to 1 to 5 V/4 to 20 mA.

Functions

The following table briefly outlines the basic functions of the C200H-AD001. These functions are covered in more detail in *2-3 Functions and Programming*.

Function	Explanation
Input range setting	The input range can be set according to the input signal level that is to be used. The same input range is used for all of the inputs for a particular Unit. The voltage range of 1 to 5 V and the current range of 4 to 20 mA, however, can be used at the user's option for any input.
Square root	Converts quadratic data, such as thermocouple input, to linear data.
Scaling	Converts an analog input signal to a preset range of BCD data for output.
Mean value	Sums the sampling data and calculates the mean value for output.
Peak value	Holds the maximum values for A/D conversion data, scaling data, mean data, and square root data, and outputs them as output data.
Disconnection detection	The Disconnection Detection Flag is turned ON and the BROKEN WIRE indicator is lit if the input signal wire becomes disconnected when 1 to 5 V/4 to 20 mA are set.

Block Diagram

The following diagram shows the basic internal configuration of the Unit.

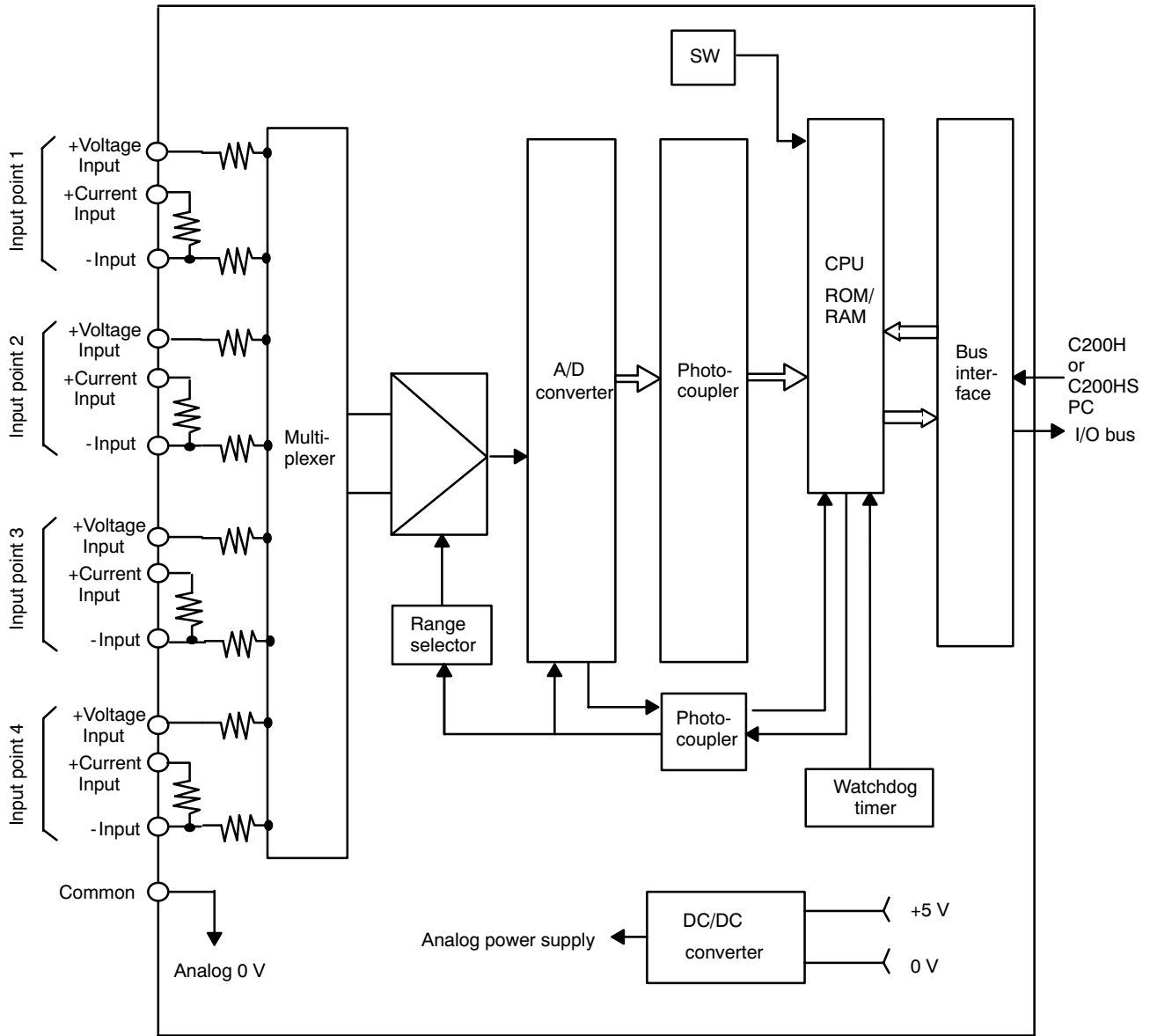

2-1-2 Switch Settings

There are four settings necessary for this Unit: unit number, number of inputs, input range, and data reading mode.

Unit Number

Unit number setting switch

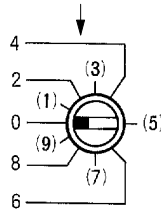

The switch notch points to the unit number. The switch in the figure to the left is set to 0. Odd numbers, in parentheses here, are not shown on the Unit.

Use a standard screwdriver and set a different unit number for each Analog I/O Unit. IR area memory is allocated according to unit number, as shown in the table below.

Switch setting	Unit number	IR words	DM words
0	Unit #0	IR 100 to 109	DM 1000 to 1099
1	Unit #1	IR 110 to 119	DM 1100 to 1199
2	Unit #2	IR 120 to 129	DM 1200 to 1299
3	Unit #3	IR 130 to 139	DM 1300 to 1399
4	Unit #4	IR 140 to 149	DM 1400 to 1499
5	Unit #5	IR 150 to 159	DM 1500 to 1599
6	Unit #6	IR 160 to 169	DM 1600 to 1699
7	Unit #7	IR 170 to 179	DM 1700 to 1799
8	Unit #8	IR 180 to 189	DM 1800 to 1899
9	Unit #9	IR 190 to 199	DM 1900 to 1999

- Note**
1. The unit number setting switch is factory set to 0.
 2. If two or more Special I/O Units are assigned the same unit number, an I/O UNIT OVER error will be generated and the PC will not operate.
 3. Make the unit number settings with the power turned off to the PC. If the settings are made with the power on, they will not go into effect until either the power is turned off and then on again or the Special I/O Unit Restart Flag (AR0100 to AR0109) is turned ON.

Number of Inputs

There can be 1, 2, or 4 inputs depending on the settings of pins 1 and 2, as shown in the table below.

0: OFF
1: ON



The following table shows the effects of the various pin combinations. If there is no need to use all of the inputs, processing time can be shortened by setting the pins so that the smallest possible number of inputs is enabled.

Pin number		Number of inputs	Inputs enabled
1	2		
OFF	ON	1	Input 1 only is enabled.
ON	OFF	2	Inputs 1 and 2 only are enabled.
OFF	OFF	4	All inputs are enabled.
ON	ON	Not used.	- - -

Input Range

Use pin 3 to set the input range.

Pin number 3	Input range	
OFF	Voltage input	1 to 5 V
	Current input	4 to 20 mA
ON	Voltage input	0 to 10 V

Note The same input range is used for all of the inputs for a particular Unit. The voltage range of 1 to 5 V and the current range of 4 to 20 mA, however, can be used at the user's option at any input.

Data Reading Mode

In normal mode, the input data is read only once before being converted from analog to digital. In filter mode, the input data is read three times and then the average values are converted from analog to digital. This helps to reduce the effects of electrical noise and so on. Using filter mode, however, results in longer processing time, as shown in the following table.

Pin number 3	Data reading mode	A/D conversion time
OFF	Normal mode	2.5 ms/input max.
ON	Filter mode	4 ms/input

2-1-3 Wiring

Terminal Allocation

The following illustration shows the function of each terminal.

Input 1 (-)	A0	B0	Voltage input 1 (+)
Not used.	A1	B1	Current input 1 (+)
Input 2 (-)	A2	B2	Voltage input 2 (+)
Not used.	A3	B3	Current input 2 (+)
Input 3 (-)	A4	B4	Voltage input 3 (+)
Not used.	A5	B5	Current input 3 (+)
Input 4 (-)	A6	B6	Voltage input 4 (+)
Not used.	A7	B7	Current input 4 (+)
Common (Analog 0 V)	A8	B8	Not used.
		B9	Common (Analog 0 V)

The same input range is used for all of the inputs for a particular Unit. The voltage range of 1 to 5 V and the current range of 4 to +20 mA, however, can be used at the user's option at any input.

Use the DIP switch on the back panel of the Unit to set the input range and the number of inputs. (For details, refer to *2-1-2 Switch Settings*.)

When current input is used, short circuit the voltage input (+) and current input (+) terminals.

The common terminal is connected to the 0 V of the Analog Input Unit's analog circuit. Noise interference can be reduced by using shielded cables for input lines.

The A8 and B9 terminals are short circuited internally.

Voltage Inputs

The following diagram illustrates the external wiring of voltage inputs for the C200H-AD001.

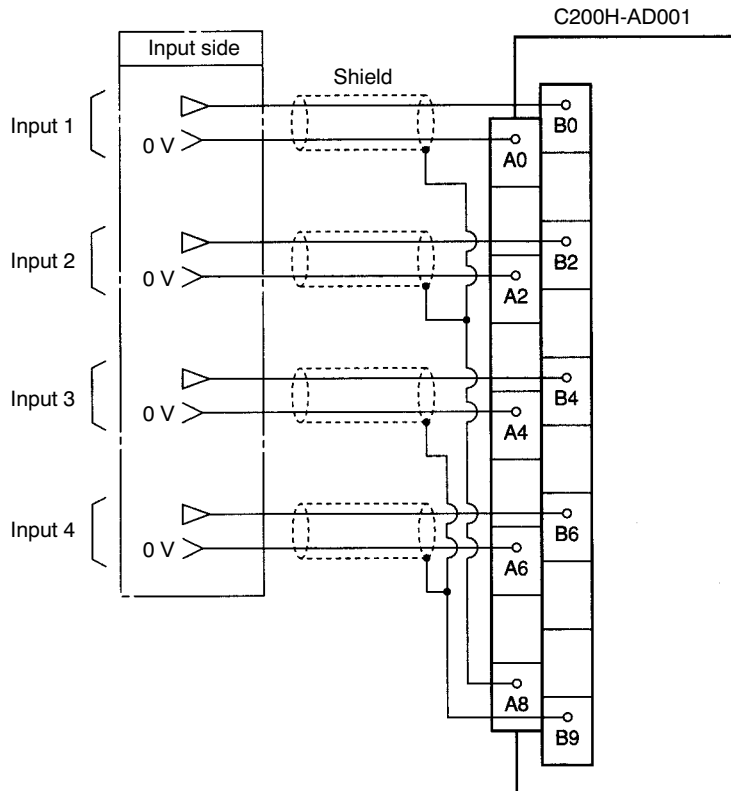

Note Terminals A8 and B9 are analog input ground terminals. They are not frame grounds and so do not connect them to a ground.

Current Inputs

The following diagram illustrates the external wiring of current inputs for the C200H-AD001. When current inputs are used, use the short pins provided with the Unit to short circuit the V+ and I+ terminals as shown in the diagram.

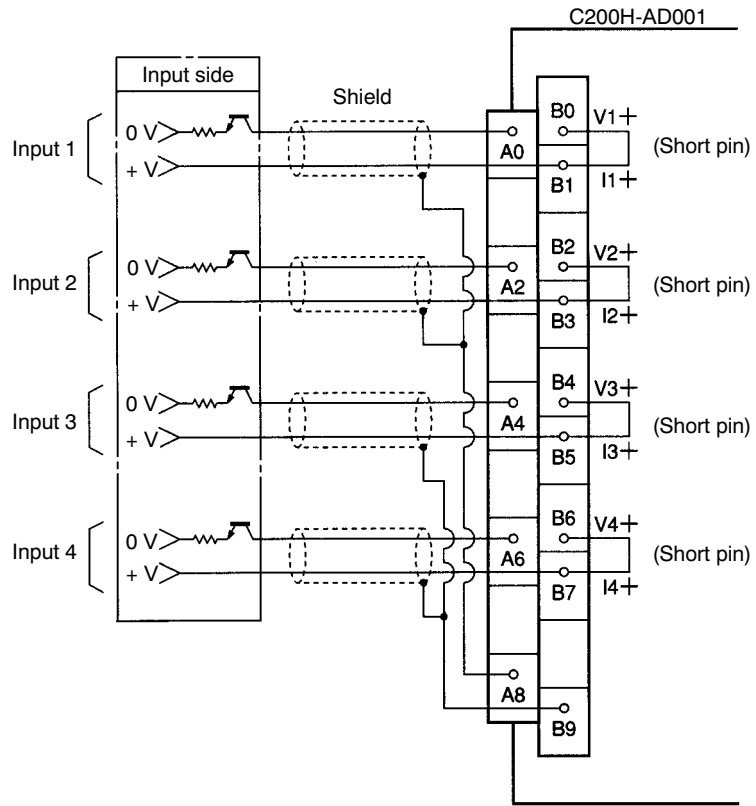

Note Terminals A8 and B9 are analog input ground terminals. They are not frame grounds and so do not connect them to a ground.

Input Wiring Considerations

When wiring inputs, apply the following points to avoid noise interference and optimize Analog Input Unit performance.

- Use shielded twisted-pair cable for external connections and power lines.
- Route input cables separately from the AC cable, and do not run the Unit's cables near a main circuit cable, high voltage cable, or a non-PC load cable.
- Be sure to install surge-absorbing diodes or surge absorbers for inductive loads (relays, solenoids, electromagnetic valves, etc.) They should be installed right next to relays and solenoids. Use surge-absorbing diodes with a dielectric strength of at least five times the circuit voltage.

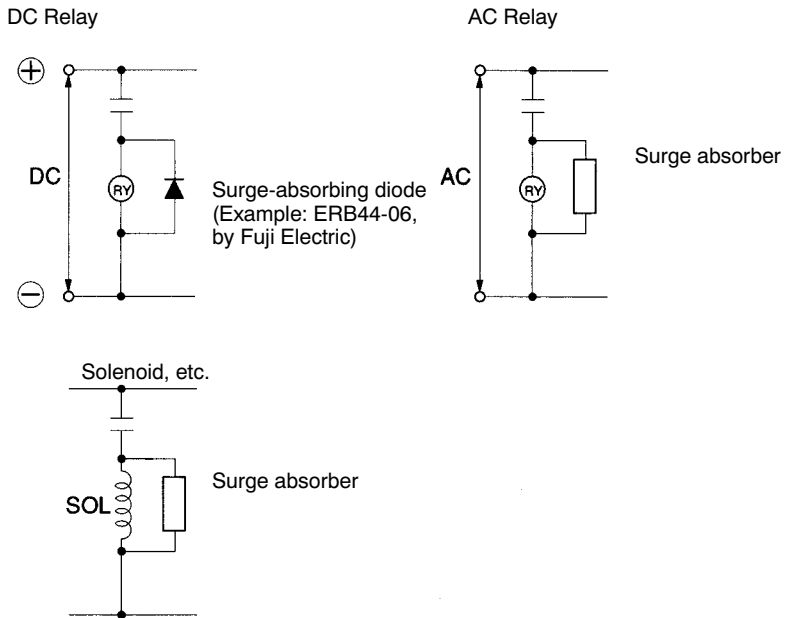

- If there is noise interference from power lines (if, for example, the power supply is shared with electrical welding devices or electrical discharge machines, or if there is a high-frequency generation source nearby) install a noise filter at the power supply input area.
- Use at least a class-3 ground (to 100 Ω or less), with as heavy a wire as possible (i.e., at least 1.25 mm²).

2-2 Bit and DM Area Allocations

IR Area Allocation

C200H Analog Input Units are allocated ten words each from the portion of the IR area (IR 100 to IR 199) that is reserved for Special I/O Units. The words that are allocated a particular Analog Input Unit depend on the setting of the unit number on the front panel of the Unit. Those ten words are then reserved as an I/O refresh data area, and the bits that comprise that area are refreshed with every I/O refresh scan by the PC.

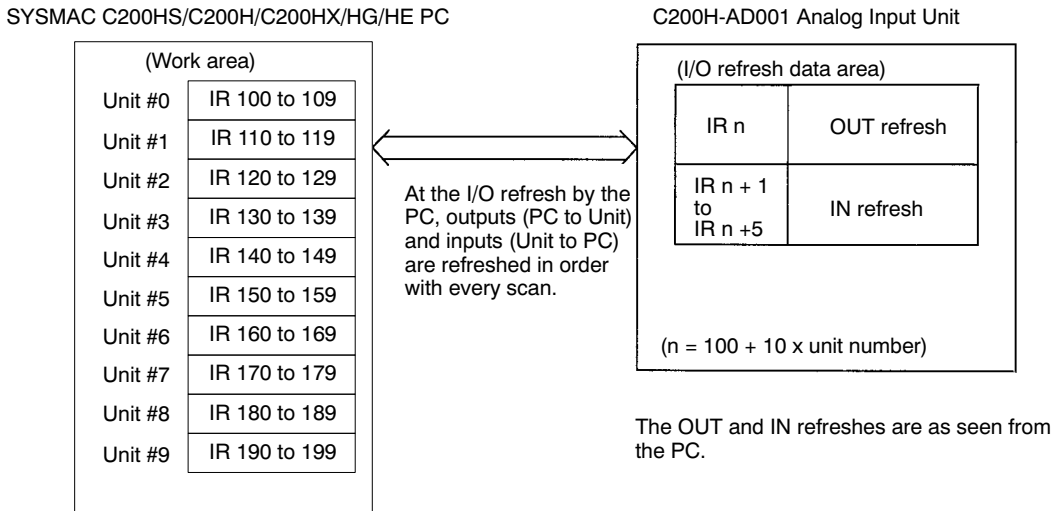

Note The unit number that is set for an Analog Input Unit must not be used for any other Special I/O Unit. If the same unit number is set more than once, an I/O UNIT OVER error will be generated and operation will be stopped.

DM Area Allocation

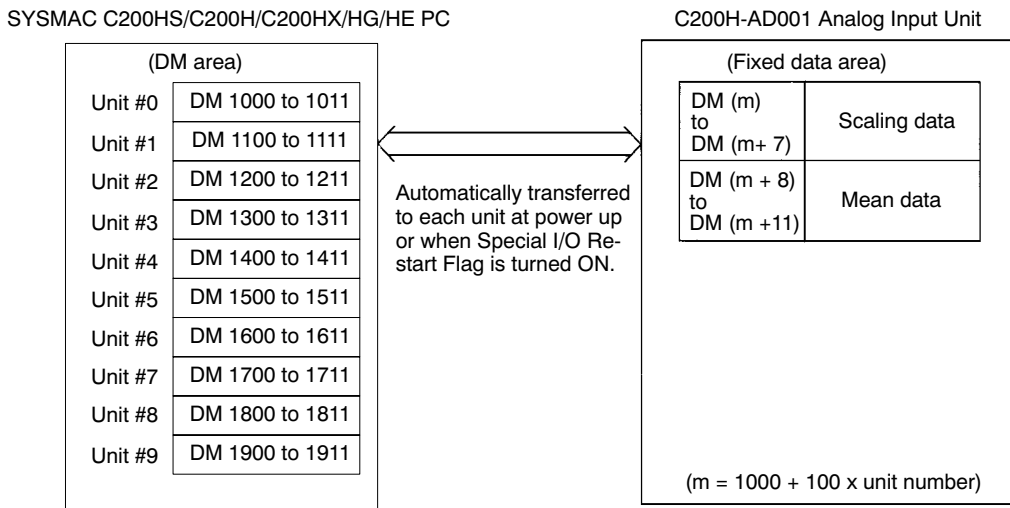

(For more information regarding DM area allocation, refer to *DM Allocations* at the end of this section.)

IR Allocations

I/O	Wd (IR)	Bit																
		15	14	13	12	11	10	09	08	07	06	05	04	03	02	01	00	
OUT	n	0	0	0	SQ	PK	Mean value processing				0	Scaling execution				OA	CP	
							Input 4	Input 3	Input 2	Input 1		Input 4	Input 3	Input 2	Input 1			
IN	n+1	Input 1 A/D conversion data or processing data																
	n+2	Input 2 A/D conversion data or processing data																
	n+3	Input 3 A/D conversion data or processing data																
	n+4	Input 4 A/D conversion data or processing data																
	n+5		0	0	0	0	0	0	0	0	OD	Input pts. 00: 4 pts. 01: 2 pts. 10: 1 pt.	IR	Disconnection detection				SE
											Input 4			Input 3	Input 2	Input 1		
n+6 to n+9		Not used.																

Note The following abbreviations are used in this table. SQ: square root calculation; PK: peak value; OA: offset adjustment; CP: A/D conversion prohibited; OD: outputs disabled; IR: input range; SE: setting error.

A/D Conversion Data

Input range	Binary data
0 to 10 V, 1 to 5 V, 4 to 20 mA	0000 to 0FA0

Processing Data

When scaling, mean value processing, peak value, or square root calculation is executed, the resulting data is output.

Note When scaling is executed, it is set in words n+1 through n+4 in BCD.

IR Area Contents: Outputs

Address		Item	Contents
Word (IR)	Bit		
n	15 to 13	---	Not used. Set each bit to 0 (i.e., OFF).
	12	Square Root ON Bit	Turn this bit ON (i.e., set it to 1) to execute the square root calculation. It is used for all inputs.
	11	Peak Value ON Bit	Turn this bit ON (i.e., set it to 1) to execute the peak value function. It is used for all inputs.
	10 to 07	Mean Value ON Bit	Turn these bits ON (i.e., set them to 1) to calculate the mean values for the respective inputs. Bits 07 to 10 correspond to inputs 1 to 4.
	06	---	Not used. Set to 0 (i.e., OFF).
	05 to 02	Scaling ON Bit	Turn these bits ON (i.e., set them to 1) to execute scaling for the respective inputs. Bits 02 to 05 correspond to inputs 1 to 4.
	01	Offset adjustment	Turn this bit ON (i.e., set it to 1) to execute the offset adjustment. The adjustment is carried out automatically at power up, so this bit does not normally need to be used.
	00	A/D conversion prohibition	Turn this bit ON (i.e., set it to 1) to prohibit A/D conversion. It is used for all inputs.

IR Area Contents: Inputs

Word (IR)	Bit	Item	Contents
n+1	15 to 00	Input 1 A/D conversion data or processing data	The A/D conversion data (binary) is set here for each input. (The data is set in BCD for scaling.)
n+2	15 to 00	Input 2 A/D conversion data or processing data	
n+3	15 to 00	Input 3 A/D conversion data or processing data	
n+4	15 to 00	Input 4 A/D conversion data or processing data	
n+5	15 to 09	- - -	Not used.
	08	Output disabled	Conversion data is unstable at power up, so this bit prohibits A/D conversion data from being output. It remains ON for approximately 100 ms after the power is turned on.
	07 to 06	Number of inputs	The number of inputs (4, 2, or 1) is determined by the status of pin numbers 1 and 2 of the DIP switch on the rear panel of the Analog Input Unit. The status of pin 2 affects bit 07, and the status of pin 1 affects bit 06.
	05	Input range	The status of this bit reflects the setting of pin 3 of the rear-panel DIP switch.
	04 to 01	Input Disconnect Flag	When an input is disconnected, the corresponding bit is turned ON (i.e., is set to 1). Bits 01 to 04 correspond to inputs 1 to 4 respectively. (See note 1.)
	00	Setting Error Flag	This bit turns ON (i.e., is set to 1) if the data set in the DM area is wrong. (See note 2.)

- Note**
- This bit turns ON under the following conditions:
 - An input is 0.5 V or less when set for 1 to 5V.
 - An input is 2 mA or less when set for 4 to 20 mA.
 - The input does not function when set for 0 to 10 V.
 - The Setting Error Flag turns ON when the scaling upper and lower limits are not in BCD or when the number of mean processing terms is 0000 or not in BCD.
 - Even if scaling or mean processing are not executed, and regardless of whether or not inputs are used, the data described in note 2 will cause the Setting Error Flag to turn ON. This will have no effect on operation, however.
 - $n = 100 + 10 \times \text{unit number}$

DM Allocations

Word	Bit															
	15	14	13	12	11	10	09	08	07	06	05	04	03	02	01	00
DM (m)	Input 1, scaling lower limit data															
DM (m+1)	Input 1, scaling upper limit data															
DM (m+2)	Input 2, scaling lower limit data															
DM (m+3)	Input 2, scaling upper limit data															
DM (m+4)	Input 3, scaling lower limit data															
DM (m+5)	Input 3, scaling upper limit data															
DM (m+6)	Input 4, scaling lower limit data															
DM (m+7)	Input 4, scaling upper limit data															
DM (m+8)	Input 1, number of samples for mean processing															
DM (m+9)	Input 2, number of samples for mean processing															
DM (m+10)	Input 3, number of samples for mean processing															
DM (m+11)	Input 4, number of samples for mean processing															

- Note**
1. The DM area that is used is a read-only area, so the data cannot be written from the program. Use the Programming Console to set data by changing the present value or changing three words together.
 2. The range for setting scaling data is 0000 to 9999 (BCD). Make sure that the lower limit is smaller than the upper limit.
 3. The range for setting the number of times that sampling is to be executed for mean value processing is 0002 to 9999 (BCD).
 4. Data that is set in the DM area is transferred either at the time of power up or when the Special I/O Unit Restart Bit is turned ON. Any data that is set in the meantime will remain invalid until then.

DM Contents

Words	Bits	Item	Data contents
DM (m) to DM (m+7)	15 to 00	Scaling data	The scaling data (upper and lower limits) is set in BCD (0000 to 9999), using two words for each input. Set the lower limit in the rightmost word and the upper limit in the leftmost word, and make sure that the lower limit is smaller than the upper limit.
DM (m+8) to DM (m+11)	15 to 00	Number of terms for calculating mean value	The number of samples to be taken for calculating the mean value is set in BCD (0002 to 9999) for each input. DM words m+8 through m+11 correspond to inputs 1 to 4.

2-3 Functions and Programming

The C200H-AD001 Analog Input Unit provides six functions:

- Input signal range setting
- Square root
- Scaling
- Mean value
- Peak value
- Input disconnection detection

These functions are set using Unit switches and Peripheral Devices, such as a Programming Console. The words allocated to the Unit in the DM Area (DM m to DM m+11) cannot be written from user program and all data set in these words must be written from a Peripheral Device.

When inputting data from a Programming Console, use the operations to change present values. When inputting from the SSS (SYSMAC Support Software), use the DM editing operations.

The data set in the DM area is transferred to the Analog Input Unit when either of the following steps is taken. Be sure to perform one or the other of these steps whenever new data has been set or data has been changed.

- Turning ON the power to the C200H/C200HS/C200HX/HG/HE CPU.
- Turning ON the Restart Bit allocated to the Unit as a Special I/O Unit (AR 0100 to 0109).

Any or all of the six functions can be used at the same time. Data will be processed in the following sequence and the final results will be output to words n+1 to n+4: analog-to-digital conversion → square root → scaling → mean value → peak value.

2-3-1 Input Signal Range Setting

The C200H-AD001 can convert analog input signals in three ranges: 0 to 10 V, 1 to 5 V, or 4 to 20 mA. The range is set on pin 3 of the DIP switch as shown below

Pin 3	Input range
OFF	1 to 5 V
	4 to 20 mA
ON	0 to 10 V

If the 0 to 10 V setting is used, it must be used for all four inputs. The 1 to 5 V and 4 to 20 mA ranges can be used at the same time for different inputs.

The digital data is in 12-bit binary code (0000 to 0FA0), and resolution is 1/4000 full scale.

Analog Input vs. Digital Output

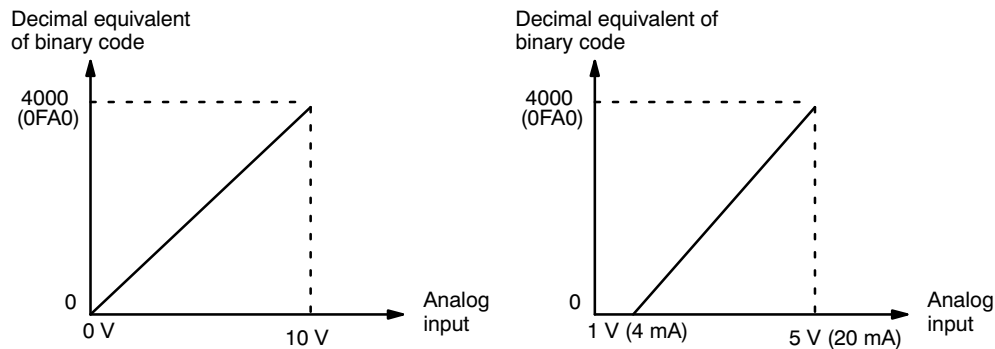

Note An offset error is likely to occur when power is turned on. The full scale of converted data is 4000, and the remaining 95 is used for offset/gain.

2-3-2 Square Root

The square root function is used to convert quadratic data, such as thermocouple inputs, to linear data. The function is activated for all inputs when the Square Root ON Bit (IR 1n012, where n is the unit number) is turned ON.

The square root function can be used at the same time as the scaling and mean value functions. If all three functions are used, the square root of the converted input value is taken first and then scaling and mean value calculations are performed.

The square root function uses an 80-bit floating decimal system. Only the integer value is kept, the remainder is truncated.

$$\text{Square root value} = \sqrt{\text{converted input value (BCD)} \times 4000}$$

Note If the Square Root ON Bit (IR 1n012, where n is the unit number) is turned ON, square root calculations will be performed for all inputs.

2-3-3 Scaling

The scaling function automatically converts the analog input signal to a preset range for use in specific engineering applications. The scaling function is executed for an input when its Scaling Bit is ON, i.e., it can be set separately for each input. This function can be used at the same time as other functions.

To set this function for an input, turn ON the Scaling Bit corresponding to that input in word n.

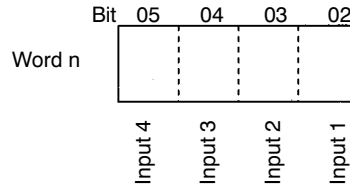

The high and low limits of the output data range for each input are 4-digit BCD values preset in the DM area, as shown in the following table (n is the unit number set on the front panel.) A lower limit must be less than the corresponding upper limit.

DM word	Range limit (BCD)	DM word	Range limit (BCD)	Bit of IR 1n0	Scaling bit
1n00	Input 1 lower limit	1n04	Input 3 lower limit	02	Input 1
1n01	Input 1 upper limit	1n05	Input 3 upper limit	03	Input 2
1n02	Input 2 lower limit	1n06	Input 4 lower limit	04	Input 3
1n03	Input 2 upper limit	1n07	Input 4 upper limit	05	Input 4

Set the scaling data with the Programming Console, this data cannot be changed from the user's program.

Data set in the DM area is transmitted when the Unit is turned on or initialized. If data is modified in the middle of a session, then the modified data becomes effective the next time the Unit is turned on, or by toggling the appropriate Special I/O Restart Bit in the AR area.

Scaled data is calculated using the formula below. Only the integer value is kept, the remainder is truncated.

$$\text{Scaling data} = \frac{\text{Input data} \times (\text{upper limit} - \text{lower limit})}{4000} + \text{lower limit}$$

Example

An example is shown below.
 Input signal range: 0 to 10 V
 Lower limit: 1000
 Upper limit: 9000

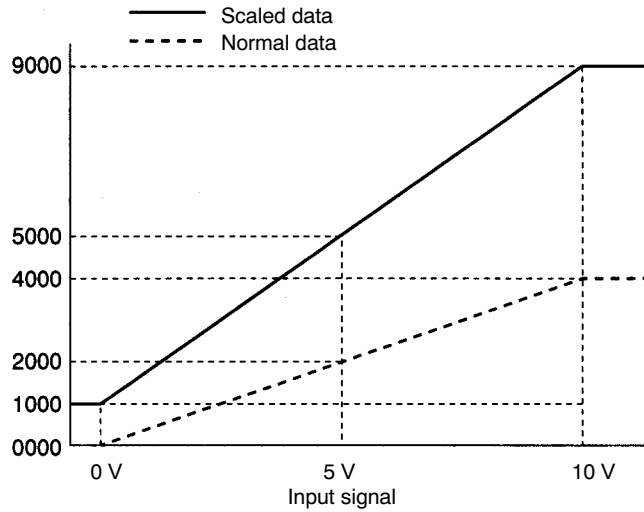

If a 5-V input is received, it would be converted to 2000 (5/10 x 4000) and then scaled as shown below.

$$\text{Scaling data} = \frac{2000 \times (9000 - 1000)}{4000} + 1000 = 5000$$

- Note**
1. Scaling will not be performed and unscaled (normal) data will be output if the contents of DM words allocated to the Unit is not BCD or if a lower limit is greater than the corresponding upper limit.
 2. The Setting Error Flag (bit 00 in IR 1n5, where n is the unit number) will be turned ON if the contents of DM m to DM m+7 is not BCD.
 3. The Setting Error Flag will turn ON whenever DM area data is not BCD regardless of whether an input is being used and regardless of whether or not scaling is set. Operation, however, will be normal in these cases.

Resolution

If the difference between an upper limit and the corresponding lower limit (upper limit - lower limit) is 4000 or greater, the resolution is fixed at 1/4000. If the difference is less than 4000, the resolution will be reduced proportionately.

For example, if the upper limit minus the lower limit is 2000, the resolution is 1/2000.

2-3-4 Mean Value

The mean value function sums a specified number of terms of converted input data and divides by the number of terms preset the DM area.

If the Mean ON Bit for an input is ON (bits 07 to 10 of word n), the mean value will be output to the corresponding word in the PC. The desired number of terms must be set in the corresponding word in the DM area between DM m+8 and DM m+11. The setting can be between 0002 and 9999 (BCD).

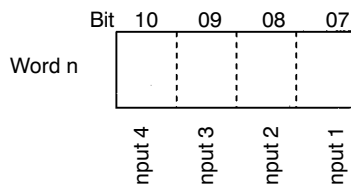

The mean value functions can be used in combination with any of the other functions.

Set the mean data for each input with the Programming Console. This data cannot be changed from the user's program. Set the mean data for all 4 inputs even when using only one input. If there is a mistake in the data for even 1 input, the Setting Error Flag will be activated, though operation will continue.

The mean value is calculated using the formula below. When the Mean Enable Bit turns ON, the converted data will read "0000" until the mean value is calculated for the first time.

$$\text{Mean value} = \frac{\text{Sum of converted input values}}{\text{Number of terms (mean data)}}$$

The maximum mean function conversion time = 2.5 ms × the sum of the number of terms for all inputs

- Note**
1. Mean value calculation will not be performed and normal data will be output if the number of terms set in the DM area is 0000 or is not BCD.
 2. The Setting Error Flag (bit 00 in IR 1n5, where n is the unit number) will be turned ON if the number of terms set in the DM area is 0000 or is not BCD.
 3. The Setting Error Flag will turn ON whenever the number of terms set in the DM area is 0000 or is not BCD regardless of whether an input is being used and regardless of whether or not scaling is set. Operation, however, will be normal in these cases.

2-3-5 Peak Value

The peak value function holds the maximum output value for every input. This function can be used at the same time as any or all of the other functions.

The output value that will be held is one of the following depending on what other functions are set: converted input value, scaled value, mean value, and square root. Data will be processed in the following sequence and the maximum value of the final results will be output to words n+1 to n+4: analog-to-digital conversion → square root → scaling → mean value → peak value.

The peak value function is activated for all 4 inputs when the Peak Value ON Bit (IR 1n011, where n is the unit number) is turned ON and reset when it is turned OFF.

- Note** If the Peak Value ON Bit (IR 1n011, where n is the unit number) is turned ON, the peak value will be held for all inputs.

Mean and Peak Values

Data will be output as illustrated below when both the mean value and the peak value functions are used. In this example, mean value #2 will be output as the first peak value even if mean value #1 is larger because the Peak Value ON Bit was turned ON after mean value #1 was output.

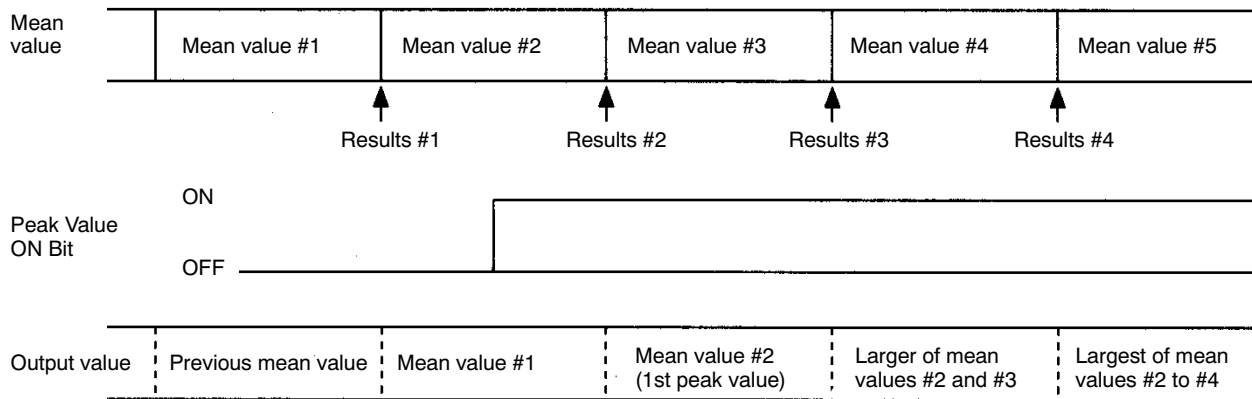

2-3-6 Input Disconnection Detection

The Input Disconnect Flags will be turned ON when an the input signal level is less than 0.5 V/2 mA and the input signal range is set at 1 to 5 V/4 to 20 mA. These flags will not turn ON when the input signal range is set at 0 to 10 V.

The Input Disconnect Flags are contained in in word IR n+5, as shown below.

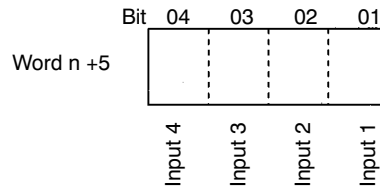

The BROKEN WIRE indicator on the Analog Input Unit will light whenever any of the Input Disconnect Flags turn ON.

- Note**
1. The Input Disconnect Flags will operate only when the Conversion Inhibit Bit (bit 00 of IR n) is OFF.
 2. Input disconnection is detected for all input set on pins 1 and 2 of the back-panel DIP switch. If an input that is not being used (i.e., not connected) is specified on the DIP switch, the Input Disconnect Flag will turn ON.
 3. The current peak value will be held even if a disconnected input is detected.

2-3-7 Data Setting Example and Programming Concepts

Data Settings

The following settings are used in this example. Data in the DM area is set using the SSS, a Programming Console, or another Peripheral Device.

Basic Settings

Turn power to the PC off then then back on or turn ON the Special I/O Unit Restart Bit allocated to the Unit (AR 0100 to AR 0109) after setting the data so that the data is read into the Analog Input Unit.

Item	Setting
Unit number	0 (allocated words: IR 100 to IR 109 and DM 1000 to DM 1011)
Inputs used	Inputs 1 to 4

Details

Item		Input 4	Input 3	Input 2	Input 1
Input signal range		1 to 5 V	4 to 20 mA	1 to 5 V	1 to 5 V
Scaling	Lower limit	---	0400	1000	1000
	Upper limit	---	1000	5000	5000
Number of terms for mean value calculation		---	50	---	10

DM Area Data

DM word	Contents	Data
DM 1000	1000	Input 1 lower limit for scaling
DM 1001	5000	Input 1 upper limit for scaling
DM 1002	1000	Input 2 lower limit for scaling
DM 1003	5000	Input 2 upper limit for scaling
DM 1004	0400	Input 3 lower limit for scaling
DM 1005	1000	Input 3 upper limit for scaling
DM 1006	0000	Input 4 lower limit for scaling
DM 1007	0000	Input 4 upper limit for scaling
DM 1008	0010	Input 1 number of terms for mean value
DM 1009	0000	Input 2 number of terms for mean value
DM 1010	0050	Input 3 number of terms for mean value
DM 1011	0000	Input 4 number of terms for mean value

Programming

The types of programming required to use an Analog Input Unit are described in this section. Refer to the operation manual for the C200H/C200HS/C200HX/HG/HE for details on programming.

Reading Output Data

The converted input value (or the results of calculations performed on it) can be read from the output words IR n+1 to IR n+4, and moved to other words in memory using MOV(21) and/or XFER(70). MOV(21) is used to move one word at a time and XFER(70) is used to move more than one word at a time.

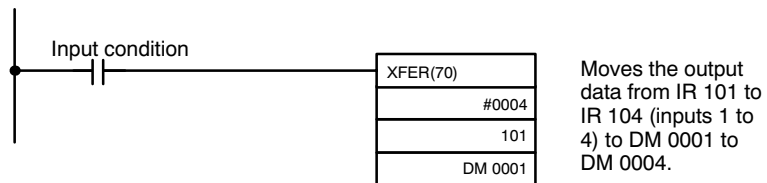
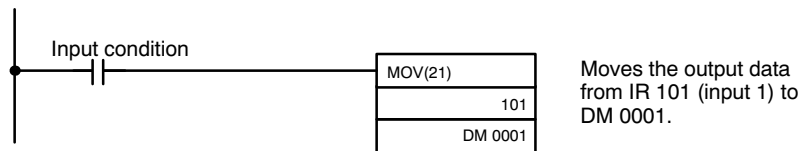

Scaling

Set 4-digit BCD values for the lower and upper limits for scaling in DM m to DM m+7. These words cannot be written from the program and must be written using a Peripheral Device, such as a Programming Console.

For example, use the following procedure to set scaling between 1000 and 5000 for input 1.

- 1, 2, 3... 1. Set the lower and upper limits in DM 1000 and DM 1001.

DM word	Contents	Data
DM 1000	1000	Input 1 lower limit for scaling
DM 1001	5000	Input 1 upper limit for scaling

2. Turn ON IR 10002 (Scaling ON Bit for input 1). Scaling will begin for input 1 as soon as this bit is turned ON. This bit can be changed from the program using the following type of programming.

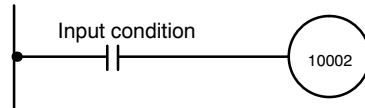

Mean Value

Set the 4-digit BCD value for the number of terms for mean value calculation in DM m+8 to DM m+11. The number of terms can be between 2 and 9999. These words cannot be written from the program and must be written using a Peripheral Device, such as a Programming Console.

For example, use the following procedure to set mean value calculation for every 10 inputs for input 1.

- 1, 2, 3... 1. Set the number of terms (10) in DM 1008.

DM word	Contents	Data
DM 1008	0010	Number of terms for mean value calculation for input 1

2. Turn ON IR 10007 (Mean Value ON Bit for input 1). Mean value calculations will begin for input 1 as soon as this bit is turned ON. This bit can be changed from the program using the following type of programming.

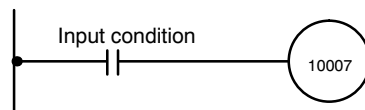

Peak Value

The peak value function can be used to hold the maximum output value for all outputs by turn ON the Peak Value ON Bit (IR10011). The peak value will be held individually for all inputs when this bit is turned ON. This bit can be changed from the program using the following type of programming.

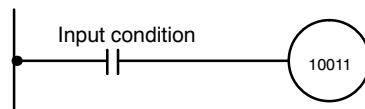

Square Root

The square root function can be used to convert quadratic data to linear data by turn ON the Square Root ON Bit (IR10012). The square root will be calculated individually for all inputs when this bit is turned ON. This bit can be changed from the program using the following type of programming.

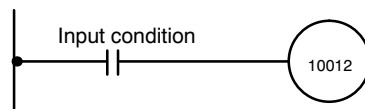

2-4 Troubleshooting

Detection When Errors Occur

When an error occurs, the contents are output to the SR and HR areas. The following tables show the various errors that may occur, along with their probable causes and remedies.

Unit error	Probable causes and operations	Possible remedies
Disconnection error	<ul style="list-style-type: none"> • Causes of error <ul style="list-style-type: none"> • Input signal wire is disconnected. • Input signal range is set to "1 to 5V" but input is 0.5 V or less. • Input signal range is set to "4 to 20 mA" but input is 2 mA or less. • Disconnect indications <ul style="list-style-type: none"> • BROKEN WIRE indicator is lit. • The Input Disconnect Flag (IR n+5, bits 01 to 04) that corresponds to the erroneous input signal is turned ON (except when the input range is 0 to 10 V). 	Check the input signal wires, terminal block, and input voltage.
Setting error	The data set in the DM area is wrong. In this case, the Setting Error Flag (IR n+5, bit 00) will be ON.	Check the contents of the data.
Output disabled	The converted data is unstable, as, for example, when the power is first turned on. In this case, the Output Disabled Flag (IR n+5, bit 08) will be ON.	---
RUN indicator not lit	The RUN indicator on the Unit is not lit even though power is turned on to the PC, and none of the errors described in this table are applicable.	Replace the Unit.

CPU error	Probable causes and operations	Possible remedies
CPU waiting	<ul style="list-style-type: none"> • The Special I/O Unit is defective. • The PC will not run. 	<ul style="list-style-type: none"> • Replace the Special I/O Unit. • The defective Unit should appear as \$ signs only in the I/O table read operation.
Duplicated unit number	One number is assigned to more than one Special I/O Unit. In this case the PC will not run and SR25415 will turn ON.	Do not assign the same number to more than one Unit. Use the I/O table read operation to display unit numbers.
Special I/O Unit error	An error has occurred in the refresh signal between the CPU and the Special I/O Unit. In this case, only the Special I/O Unit stops. SR 25415 is turned ON.	Check AR 0000 to AR 0009 for the unit number of the Unit in error. After correcting the error, set restart (OFF →ON →OFF) in AR 0100 to AR 0109. If the error does not clear after initialization, replace the Unit.

Special I/O Unit Error Detection Bit (SR)

Bit	Error	Explanation	Operation status
SR 25415	Duplicated unit number	The same number is assigned to more than one Special I/O Unit.	PC operation stops.
	Special I/O Unit error	An error has occurred in the refresh signal between the CPU and the Special I/O Unit	Operation stops only for the faulty Unit.

Special I/O Unit Error Flags (AR)

Bit	Item	Function
AR 0000	Unit #0 Error Flag	When one of the CPU errors described above occurs, the AR bit turns ON for the Unit where the error occurred.
AR 0001	Unit #1 Error Flag	
AR 0002	Unit #2 Error Flag	
AR 0003	Unit #3 Error Flag	
AR 0004	Unit #4 Error Flag	
AR 0005	Unit #5 Error Flag	
AR 0006	Unit #6 Error Flag	
AR 0007	Unit #7 Error Flag	
AR 0008	Unit #8 Error Flag	
AR 0009	Unit #9 Error Flag	

Special I/O Unit Restart Bits (AR)

Turn ON the Special I/O Unit Restart Bits in the following circumstances:

- After DM data has been set or replaced.
- To restart Unit operation after clearing an error.

The same effect can be achieved by turning off the power to the PC and then turning it on again.

Bit	Item	Function
AR 0100	Unit #0 Restart Bit	Special I/O Units can be restarted by turning the corresponding bits ON.
AR 0101	Unit #1 Restart Bit	
AR 0102	Unit #2 Restart Bit	
AR 0103	Unit #3 Restart Bit	
AR 0104	Unit #4 Restart Bit	
AR 0105	Unit #5 Restart Bit	
AR 0106	Unit #6 Restart Bit	
AR 0107	Unit #7 Restart Bit	
AR 0108	Unit #8 Restart Bit	
AR 0109	Unit #9 Restart Bit	

SECTION 3

C200H-DA001 Analog Output Units

This section provides the information required to install and operate a C200H-DA001 Analog Output Unit.

3-1	Before Operation	30
3-1-1	Nomenclature and Functions	30
3-1-2	Switch Settings	32
3-1-3	Wiring	33
3-2	Bit and DM Allocations	36
3-3	Functions and Programming	38
3-3-1	Output Signal Range Setting	39
3-3-2	Output Limits	39
3-3-3	Output Limit Alarms	41
3-3-4	Pulse Output	42
3-3-5	Data Setting Example and Programming Concepts	43
3-4	Troubleshooting	45

3-1 Before Operation

3-1-1 Nomenclature and Functions

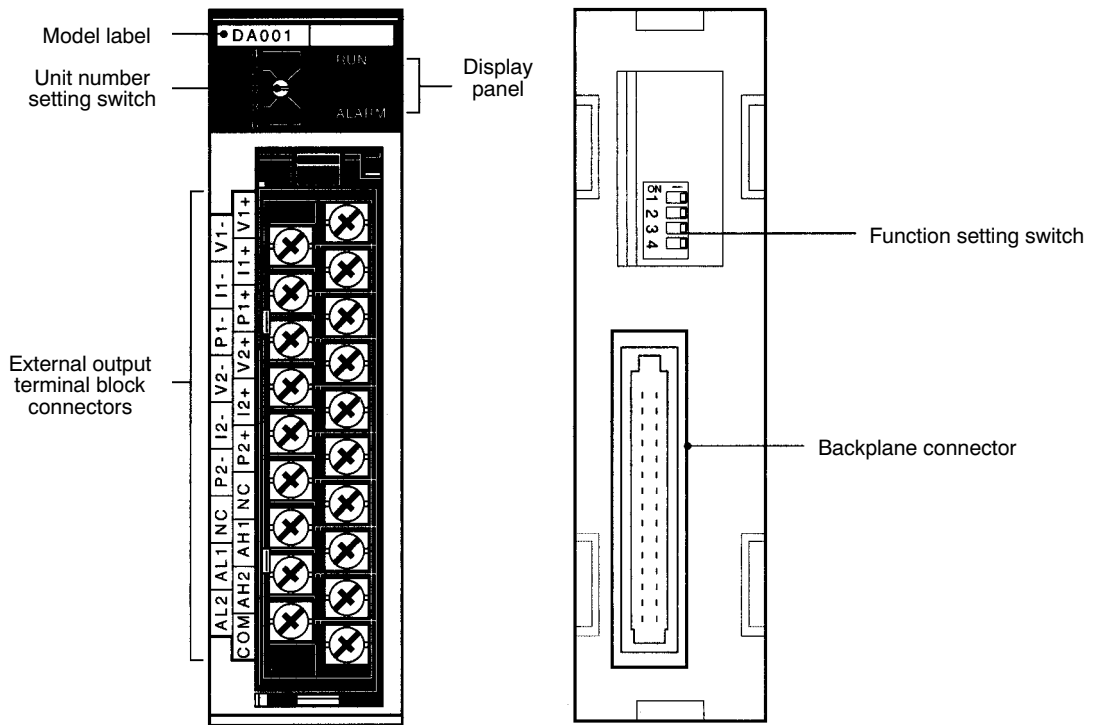

Indicators

Indicator	Color	Function
RUN	Green	Lit when the Analog Output Unit is operating correctly. If operation is not normal, this indicator turns OFF and Unit operation is stopped.
ALARM	Red	Lit when an alarm is output as a result of the upper or lower limits being exceeded,

Functions

The following table briefly outlines the basic functions of the C200H-DA001. These functions are covered in more detail in 3-3 *Functions and Programming*.

Function	Explanation
Output range setting	The output range can be set according to the output signal level that is to be used. The same output range is used for all of the outputs for a particular Unit. The voltage range of 1 to 5 V and the current range of 4 to 20 mA, however, can be used at the user's option at any output.
Output limit	The output limit function sets upper and lower limits on the output signal. The upper and lower limits are preset in the DM area. The output remains at the limit level as long as the output limit function is activated.
Output limit alarm	This function activates an alarm if the output signal is outside of the range defined by the upper and lower limits preset in the DM area, but it does not alter the output level. It is possible to include a deadband, which delays the resetting of the alarm. The output limit alarm turns ON and OFF according to the following conditions.
Pulse output	This function creates a 0 V to 5 V pulse output separate from the analog output.

Block Diagram

The following diagram shows the basic internal configuration of the Analog Output Unit.

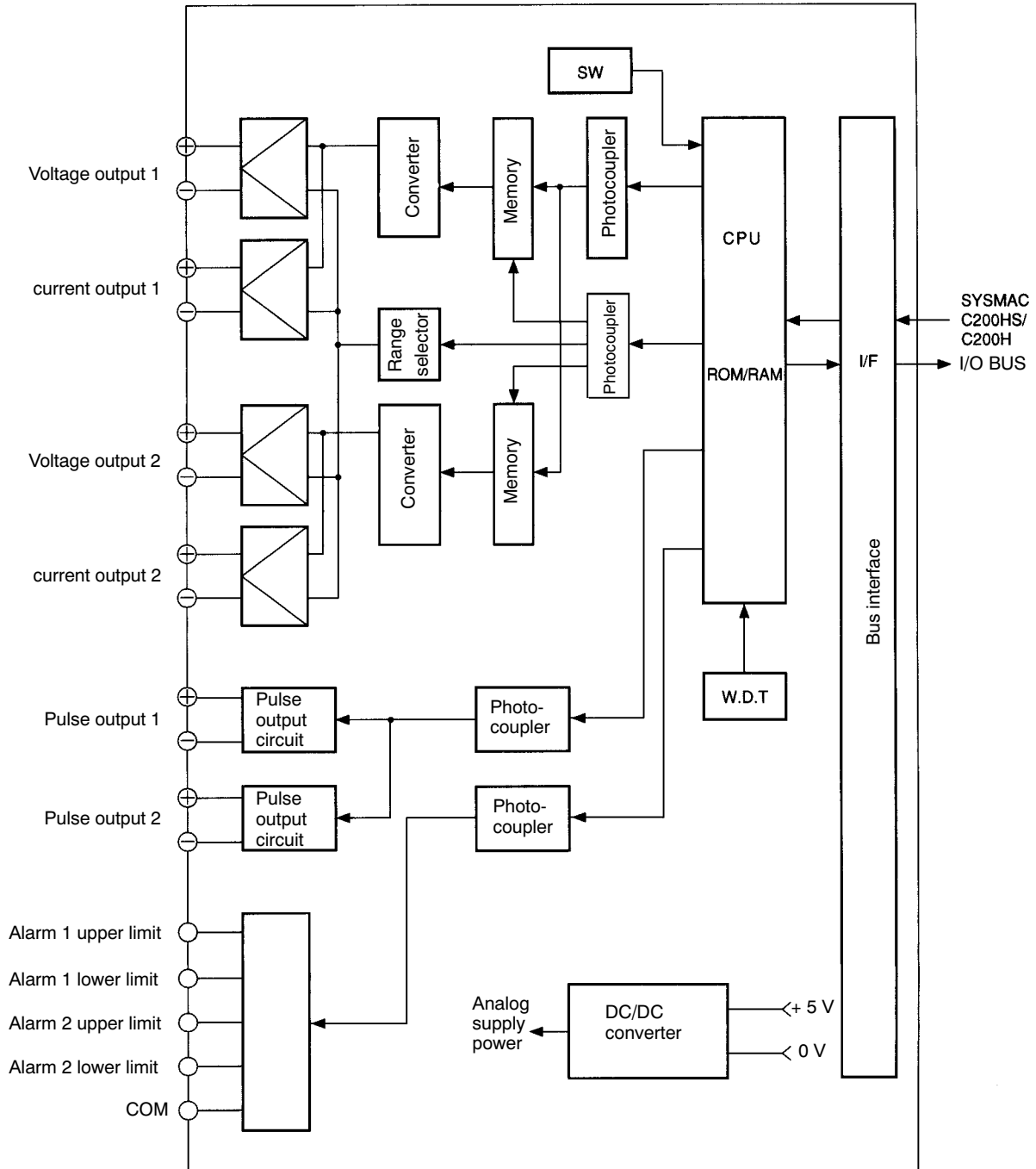

3-1-2 Switch Settings

There are four settings necessary for this Unit: unit number, output range, pulse output line, and pulse output ON/OFF.

Unit Number

Unit number setting switch

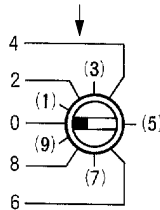

The switch notch points to the unit number. The switch in the figure to the left is set to 0. Odd numbers, in parentheses here, are not shown on the Unit.

Use a standard screwdriver to set a different unit number for each Analog I/O Unit. IR area memory is allocated according to unit number, as shown in the table below.

Switch number	Unit number	IR words	DM words
0	Unit #0	IR 100 to 109	DM 1000 to 1099
1	Unit #1	IR 110 to 119	DM 1100 to 1199
2	Unit #2	IR 120 to 129	DM 1200 to 1299
3	Unit #3	IR 130 to 139	DM 1300 to 1399
4	Unit #4	IR 140 to 149	DM 1400 to 1499
5	Unit #5	IR 150 to 159	DM 1500 to 1599
6	Unit #6	IR 160 to 169	DM 1600 to 1699
7	Unit #7	IR 170 to 179	DM 1700 to 1799
8	Unit #8	IR 180 to 189	DM 1800 to 1899
9	Unit #9	IR 190 to 199	DM 1900 to 1999

- Note**
1. The unit number setting switch is factory set to 0.
 2. If two or more Special I/O Units are assigned the same unit number, an I/O UNIT OVER error will be generated and the PC will not operate.
 3. Make the unit number settings with the power turned off to the PC. If the settings are made with the power on, they will not go into effect until either the power is turned off and then on again or the Special I/O Unit Restart Flag (AR0100 to AR0109) is turned ON.

DIP Switch Settings

Set pins 1 through 3 before powering up the system. Pin 4 is not used, so please leave it set to OFF.

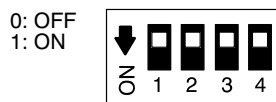

Output Range

Use pin 1 to set the output range.

Pin number 3	Output range	
OFF	Voltage input	1 to 5 V
	Current input	4 to 20 mA
ON	Voltage input	0 to 10 V

- Note** The same output range is used for all of the outputs for a particular Unit. The voltage range of 1 to 5 V and the current range of 4 to 20 mA, however, can be used at the user's option at any output.

Pulse Output Line Use pin 2 to set the pulse output line.
 Pin 2 OFF: Output 1
 Pin 2 ON: Output 2

Pulse Output ON/OFF Use pin 3 to set pulse outputs to ON or OFF.
 Pin 3 OFF: Pulse output OFF
 Pin 3 ON: Pulse output ON

3-1-3 Wiring

Terminal Allocation The following illustration shows the function of each output.

		B0	Voltage output 1 (+)
Voltage output 1 (-)	A0	B1	Current output 1 (+)
Current output 1 (-)	A1	B2	Pulse output 1 (+)
Pulse output 1 (-)	A2	B3	Voltage output 2 (+)
Voltage output 2 (-)	A3	B4	Current output 2 (+)
Current output 2 (-)	A4	B5	Pulse output 2 (+)
Pulse output 2 (-)	A5	B6	Not used.
Not used.	A6	B7	Upper limit alarm output 1
Lower limit alarm output 1	A7	B8	Upper limit alarm output 2
Lower limit alarm output 2	A8	B9	Alarm output common

The Analog Output Unit has two built-in output lines, but it is not possible to simultaneously use one of them for both voltage and current outputs.

The same output range is used for all of the outputs for a particular Unit. The voltage range of 1 to 5 V and the current range of 4 to 20 mA, however, can be used at the user's option at any output.

Pulse output is possible for either output 1 or output 2, but not for both. Refer to *3-1-2 Switch Settings* for details.

Output Wiring

The following diagram shows the external wiring of outputs for the C200H-DA001.

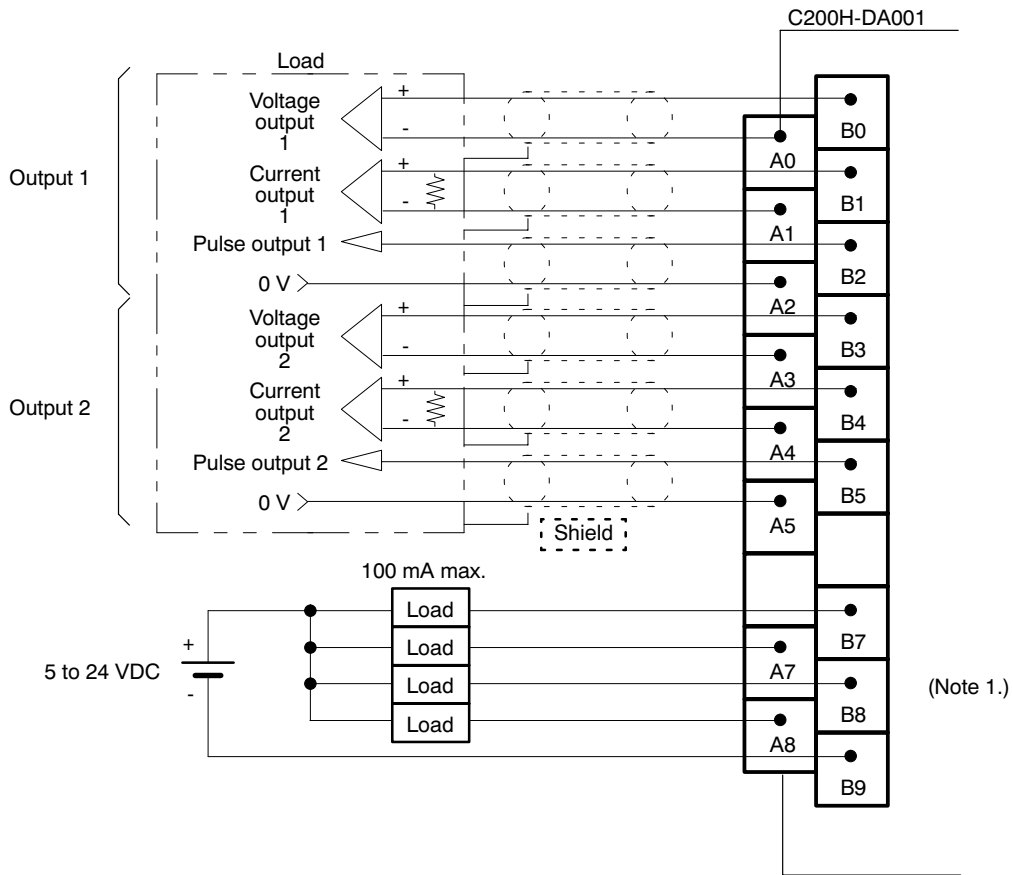

- Note**
1. The maximum current capacity for this alarm output (open-collector output) is 100 mA/circuit.
 2. A single output line cannot be used for voltage and current output at the same time.

Output Wiring Considerations

When wiring outputs, apply the following points to avoid noise interference and optimize Analog Output Unit performance.

- Use shielded twisted-pair cable for external connections and power lines.
- Route output cables separately from the AC cable, and do not run the Unit's cables near a main circuit cable, high voltage cable, or a non-PC load cable.
- Be sure to install surge-absorbing diodes or surge absorbers for inductive loads (relays, solenoids, electromagnetic valves, etc.) They should be installed right next to relays and solenoids. Use surge-absorbing diodes with a dielectric strength of at least five times the circuit voltage.

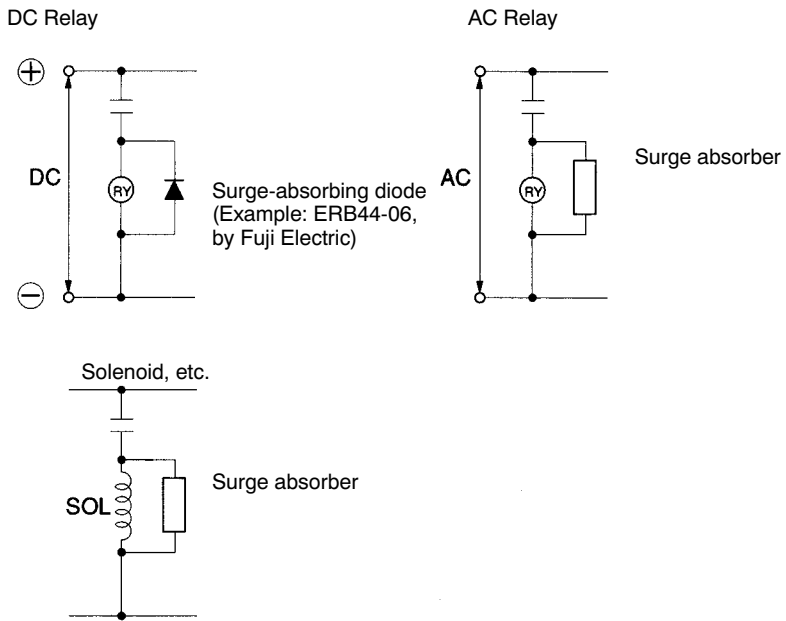

- If there is noise interference from power lines (if, for example, the power supply is shared with electrical welding devices or electrical discharge machines, or if there is a high-frequency generation source nearby) install a noise filter at the power supply output area.
- Use at least a class-3 ground (to 100 Ω or less), with as heavy a wire as possible (i.e., at least 1.25 mm²).

Caution

When using the C200H-DA001 Analog Output Unit, a voltage (current) may be output momentarily from the output terminal when the power supply to the PC is turned ON or OFF.

Approximately 10 V will be output for approximately 1 second after the power is turned ON or OFF.

If this causes a problem, provide countermeasures so that the power supply or output timing of external devices differs from the ON/OFF timing of the power supply to the PC.

3-2 Bit and DM Allocations

IR Allocations

C200H/C200HS Analog Output Units are allocated ten words each from the portion of the IR area (IR 100 to IR 199) that is reserved for Special I/O Units. The words that are allocated a particular Analog Output Unit depend on the setting of the unit number setting switch on the front panel of the Unit. Those ten words are then reserved as an I/O refresh data area, and the bits that comprise that area are refreshed with every I/O refresh scan by the PC.

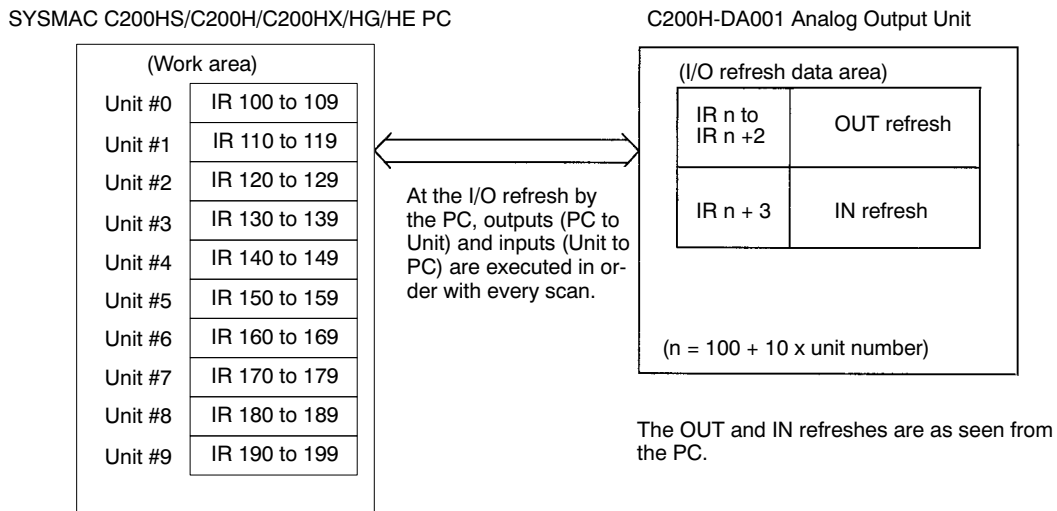

Note The unit number that is set for an Analog Input Unit must not be used for any other Special I/O Unit. If overlapping numbers are set, an I/O UNIT OVER error will be generated and operation will be stopped.

DM Allocations

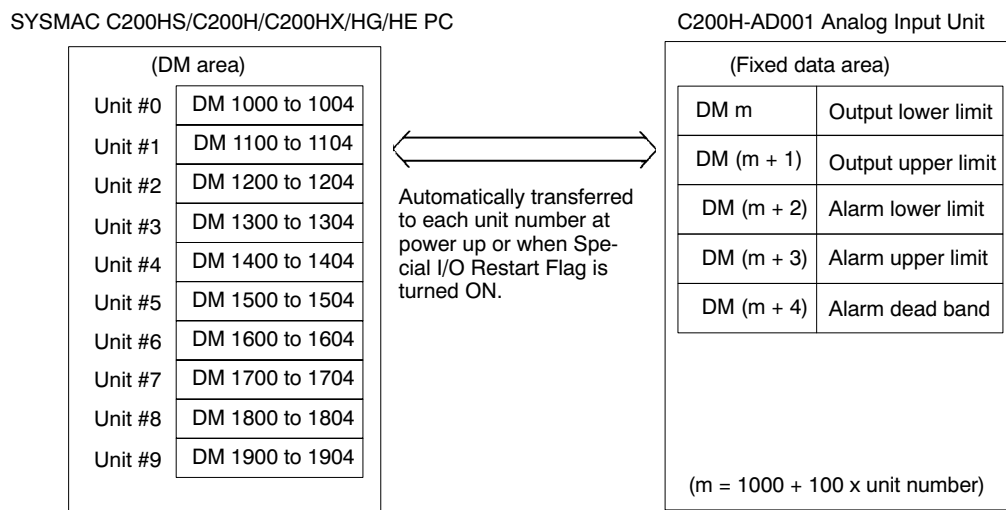

(For more information regarding DM address allocation, refer to the DM Address Allocation Chart at the end of this section.)

IR Allocations

I/O	Wd (IR)	Bit															
		15	14	13	12	11	10	09	08	07	06	05	04	03	02	01	00
OUT	n	Output 1 setting data (0000 to 0FFF); (Becomes duty ratio data for pulse output.)															
	n+1	Output 2 setting data (0000 to 0FFF); (Becomes duty ratio data for pulse output.)															
	n+2	0				0	0	0	OP	O2L	O1L	O2A	O1A	0	Pulse cycle 100: 20 s 011: 10 s 010: 5 s 001: 2 s 000: 1 s		
IN	n+3	0				0	0	0	Output 2 limit detected		Output 1 limit detected		Output 2 alarm		Output 1 alarm		SE
		UL	LL	UL	LL	UL	LL	UL	LL								
	n+4 to n+9	Not used.															

Note The following abbreviations are used in this table. OP: output prohibited; O2L: output 2 limit; O1L: output 1 limit; UL: upper limit; LL: lower limit; SE: setting error.

IR Area Contents (Outputs)

Address		Item	Contents																									
Word (IR)	Bit																											
n	15 to 00	Output 1 setting data	Sets output 1 data in binary. This becomes duty ratio data when pulse outputs are set. The range is 0000 to 0FFF.																									
n+1	15 to 00	Output 2 setting data	Sets output 2 data in binary. This becomes duty ratio data when pulse outputs are set. The range is 0000 to 0FFF.																									
n+2	15 to 09	---	Not used. Set all bits to "0."																									
	08	Output prohibited	Turn ON to prohibit outputs. This bit is used for outputs 1 and 2.																									
	07	Output 2 limit	Turn ON to execute output 2 limit.																									
	06	Output 1 limit	Turn ON to execute output 1 limit.																									
	05	Output 2 alarm	Turn ON to execute output 2 alarm.																									
	04	Output 1 alarm	Turn ON to execute output 1 alarm.																									
	03	---	Not used. Turn OFF (i.e., set to "0").																									
	02 to 00	Pulse cycle	Sets the pulse period. <table border="1" style="margin-left: 20px;"> <thead> <tr> <th colspan="2">Pulse period</th> <th>1 s</th><th>2 s</th><th>5 s</th><th>10 s</th><th>20 s</th> </tr> </thead> <tbody> <tr> <td rowspan="3">Bit</td> <td>02</td> <td>0</td><td>0</td><td>0</td><td>0</td><td>1</td> </tr> <tr> <td>01</td> <td>0</td><td>0</td><td>1</td><td>1</td><td>0</td> </tr> <tr> <td>00</td> <td>0</td><td>1</td><td>0</td><td>1</td><td>0</td> </tr> </tbody> </table>	Pulse period		1 s	2 s	5 s	10 s	20 s	Bit	02	0	0	0	0	1	01	0	0	1	1	0	00	0	1	0	1
Pulse period		1 s	2 s	5 s	10 s	20 s																						
Bit	02	0	0	0	0	1																						
	01	0	0	1	1	0																						
	00	0	1	0	1	0																						

IR Area Contents (Inputs)

Word (IR)	Bit	Item	Contents
n+3	15 to 09	- - -	Not used.
	08	Output 2 limit detected	Upper limit: Turns ON when output 2 value is greater than the upper limit.
	07		Lower limit: Turns ON when output 2 value is less than the lower limit.
	06	Output 1 limit detected	Upper limit: Turns ON when output 1 value is greater than the upper limit.
	05		Lower limit: Turns ON when output 1 value is less than the lower limit.
	04	Output 2 alarm (See note.)	Upper limit: Turns ON when output 2 value is greater than the alarm upper limit.
	03		Lower limit: Turns ON when output 2 value is less than the alarm lower limit.
	02	Output 1 alarm (See note.)	Upper limit: Turns ON when output 1 value is greater than the alarm upper limit.
	01		Lower limit: Turns ON when output 1 value is less than the alarm lower limit.
	00	Setting error	This bit turns ON if the data set in the DM area is wrong. (See note 2.)

Note When alarm flags turn ON, their status can be read from external connection terminals A7, A8, B7, and B8. (Refer to 3-1-3 Wiring.) At that time the ALARM indicator on the display panel of the Unit will light.

DM Allocations

Word	Bit															
	15	14	13	12	11	10	09	08	07	06	05	04	03	02	01	00
DM m	Output lower limit (0000 to 0FFF)															
DM (m+1)	Output upper limit (0000 to 0FFF)															
DM (m+2)	Alarm lower limit (0000 to 0FFF)															
DM (m+3)	Alarm upper limit (0000 to 0FFF)															
DM (m+4)	Alarm dead band (0000 to 0FFF)															

- Note**
1. The DM area that is used is a read-only area, so the data cannot be written from the program. Use the Programming Console to set data by changing the present value or changing three words together.
 2. Data that is set in the DM area is transferred either at the time of power up or when the Special I/O Unit Restart Bit is turned ON. Any data that is set in the meantime will remain invalid until then.
 3. The values set in DM are used for both output lines (i.e., for output 1 and output 2).
 4. $m = 1000 + 100 \times \text{unit number}$.

3-3 Functions and Programming

The C200H-DA001 Analog Output Unit provides 4 functions

- Output signal range setting
- Output limit
- Output limit alarm
- Pulse output

These functions are set using Unit switches and Peripheral Devices, such as a Programming Console. The words allocated to the Unit in the DM Area (DM m to DM m+4) cannot be written from user program and all data set in these words must be written from a Peripheral Device.

When inputting data from a Programming Console, use the operations to change present values. When inputting from the SSS (SYSMAC Support Software), use the DM editing operations.

The data set in the DM area is transferred to the Analog Output Unit when either of the following steps is taken. Be sure to perform one or the other of these steps whenever new data has been set or data has been changed.

- Turning ON the power to the C200H/C200HS CPU.
- Turning ON the Restart Bit allocated to the Unit as a Special I/O Unit (AR 0100 to 0109).

3-3-1 Output Signal Range Setting

The C200H-DA001 converts 12-bit binary data (3-digit hexadecimal) from the PC to analog output in one of three ranges: 0 to 10 V, 1 to 5 V, or 4 to 20 mA.

The C200H-DA001 can convert analog output signals in three ranges: 0 to 10 V, 1 to 5 V, or 4 to 20 mA. The range is set on pin 1 of the DIP switch as shown below.

Pin 1	Input range
OFF	1 to 5 V
	4 to 20 mA
ON	0 to 10 V

If the 0 to 10 V setting is used, it must be used for all two outputs. The 1 to 5 V and 4 to 20 mA ranges can be used at the same time for different outputs.

Digital Output vs. Analog Input

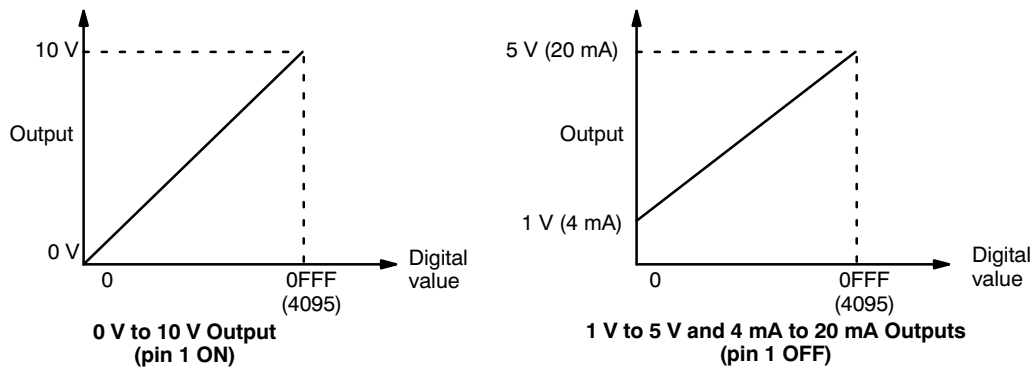

3-3-2 Output Limits

The output limit function can be used to establish upper and lower limits for the output signal. The limits can be used to restrict the output for any of a number of possible reasons, e.g., to prevent unsuitable outputs from occurring even when incorrect data is set.

This function can be used at the same time as the output limit alarm function.

The upper and lower limits are preset as binary values in the DM area (lower limit in DM m and upper limit in DM m+1). The output will remain between the upper and lower limits as long as the output limit function is activated.

If the output goes beyond either limit, an Output Limit Flag (bits 05 to 08 in IR n+3) will turn ON and the output will remain at the limit value

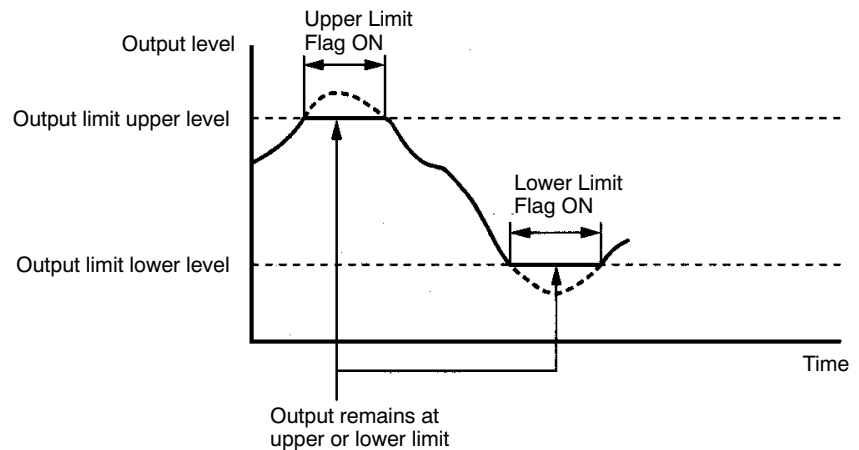

Use the following procedure to set upper and lower limits.

- 1, 2, 3... 1. Set the lower and upper limits in DM m and DM m+1. The setting range is between 0000 and 0FFF (binary data). Set the limits from the Programming Console. This data cannot be changed from the user's program.

Note Calculations of the desired limit can be made as shown in the following example. To set an upper limit of 8 V for a 0 to 10 V range setting, use the following equation and set the results (0CCC) in DM m+1:
 $8/10 \times 0FFF = 0CCC$
2. Turn power to the PC off then then back on or turn ON the Special I/O Unit Restart Bit allocated to the Unit (AR 0100 to AR 0109).
3. Turn ON the Output Limit ON Bit for the desired output:
 - Output 1 Limit ON Bit: Bit 06 of IR n+2
 - Output 2 Limit ON Bit: Bit 07 of IR n+2

3-3-3 Output Limit Alarms

This function activates an alarm if the output signal is outside of the range defined by the upper and lower limits preset in the DM area, but it does not alter the output level. It is possible to include a deadband, which delays the resetting of the alarm.

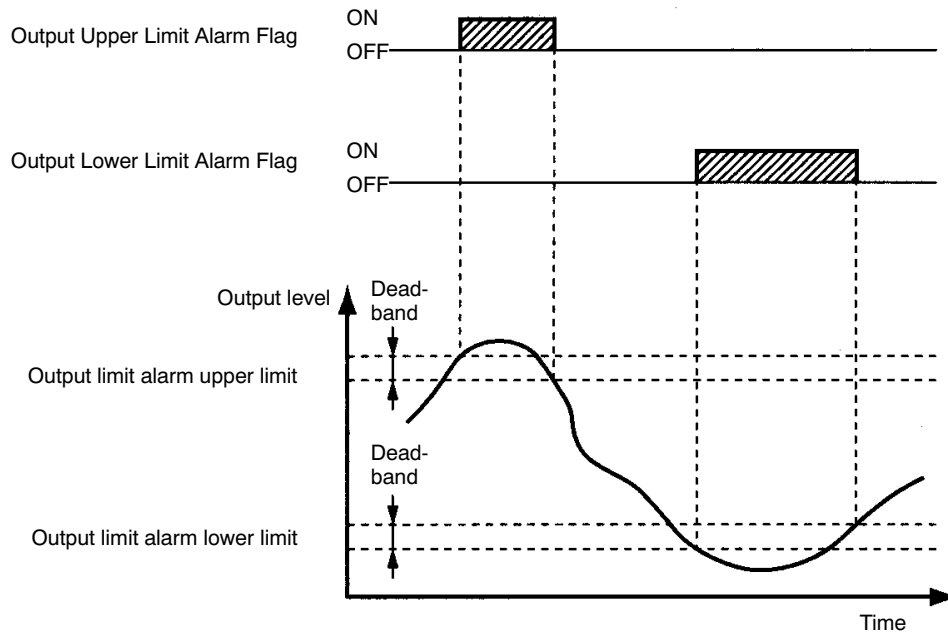

This function can be used at the same time as the output limit function. The output limit alarms turn ON and OFF according to the following conditions.

Upper limit:

ON: analog output \geq output limit alarm upper limit

OFF: analog output $<$ output limit alarm upper limit - deadband width

Lower limit:

ON: analog output \leq output limit alarm lower limit

OFF: analog output $>$ output limit alarm lower limit + deadband width

When any of the Output Limit Alarm Flags turn ON, the ALARM indicator on the Unit will light and signals will be generated on external terminals A7, A8, B7, and B8 (refer to 3-1-3 Wiring for details).

Use the following procedure to set upper and lower limit alarms.

1, 2, 3...

1. Set the lower and upper alarm limits in DM m+2 to DM m+4. The setting range is between 0000 and 0FFF (binary data). Set the limits from the Programming Console. This data cannot be changed from the user's program.

Note Calculations of the desired limit can be made as shown in the following example. To set an upper limit alarm at 4.75 V for a 1 to 5 V range setting, use the following equation and set the results (0F00) in DM m+1: $(4.75 - 1)/(5 - 1) \times 0FFF = 15/16 \times 0FFF = 0F00$

2. Turn power to the PC off then then back on or turn ON the Special I/O Unit Restart Bit allocated to the Unit (AR 0100 to AR 0109).
3. Turn ON the Output Alarm ON Bit for the desired output:
 - Output 1 Alarm ON Bit: Bit 04 of IR n+2
 - Output 2 Alarm ON Bit: Bit 05 of IR n+2

3-3-4 Pulse Output

The pulse output function can be used to create a 0 to 5 V pulse output for either output 1 or 2 in addition to the analog output.

The pulse period and duty ratio (ON/OFF ratio) can be set for the pulse output. These settings can be made from the user program.

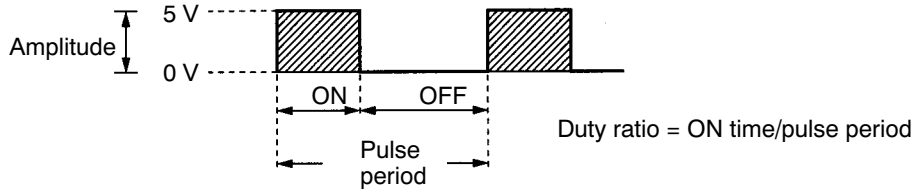

Note The resolution of the duty ratio is 1/256.

Use the following procedure to set a pulse output.

- 1, 2, 3... 1. Turn ON pin 3 of the DIP switch on the back of the Unit to select pulse output.
2. Turn OFF pin 2 to select output 1, or ON to select output 2. Both outputs cannot be pulse at the same time.
3. Set the pulse period in bits 00 to 02 of IR n+2 as shown below.

Bis in IR n			Period
00	01	02	
0	0	0	1 s
1	0	0	2 s
0	1	0	5 s
1	1	0	10 s
0	0	1	20 s

4. Set the duty ratio (ON/OFF ratio) for the pulse output in IR n. Refer to 3-3-5 *Data Setting Example and Programming Concepts* for setting methods.

Calculating Settings

To set a duty ratio of 80% , set the results of the following calculation (0CCC) in IR n: $80/100 \times 0FFF = 0CCC$.

If either the duty ratio or period is changed during operation, the output will not change until 1 full period has been completed.

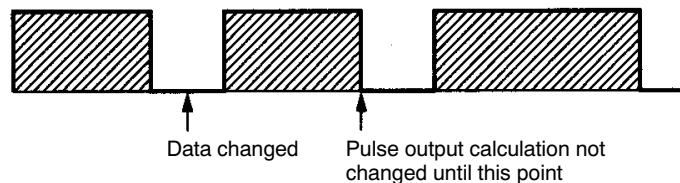

3-3-5 Data Setting Example and Programming Concepts

Data Settings

The following settings are used in this example. Data in the DM area is set using the SSS, a Programming Console, or another Peripheral Device. Turn power to the PC off then then back on or turn ON the Special I/O Unit Restart Bit allocated to the Unit (AR 0100 to AR 0109) after setting the data so that the data is read into the Analog Output Unit.

Item	Setting
Unit number	0 (allocated words: IR 100 to IR 109 and DM 1000 to DM 1004)

Item	Output 1	Output 2
DM word for storing output data	DM 0000	DM 0001
Lower limit output bit	IR 00100	---
Upper limit output bit	IR 00101	---
Lower limit alarm output terminal	---	A8
Upper limit alarm output terminal	---	B8

Details

Item	Output 1	Output 2
Output signal range	1 to 5 V	4 to 20 mA
Output limit function	ON	OFF
Limit alarm function	OFF	ON

Item	Actual value	Setting
Output limits	Lower limit	1.25 V
	Upper limit	4.75 V
Alarm limits	Lower limit	6 mA
	Upper limit	19 mA
	Deadband	0.5 mA

DM Area Settings

DM word	Data	Setting
DM 1000	0100	Output limit lower limit
DM 1001	0F00	Output limit upper limit
DM 1002	0200	Alarm lower limit
DM 1003	0F00	Alarm upper limit
DM 1004	0080	Deadband for alarm

Programming

The types of programming required to use an Analog Output Unit are described in this section. Refer to the operation manual for the C200H/C200HS for details on programming.

Writing Output Data

Output data can be written using instructions like MOV(21) and OUT. The following instruction move the binary contents of DM 0000 and DM 0001 to IR 100 and IR 101, causing the data to be converted to analog signals and to be sent to outputs 1 and 2.

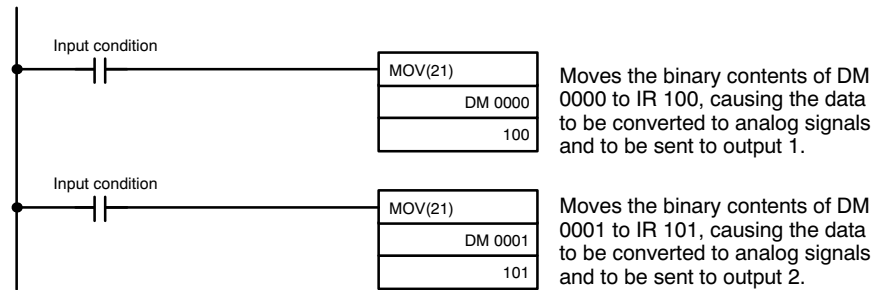

Limiting Outputs

This example assumes that the data settings given at the beginning of this section have already been made.

The output will be limited to between 1.25 and 4.75 V when the following instructions are executed.

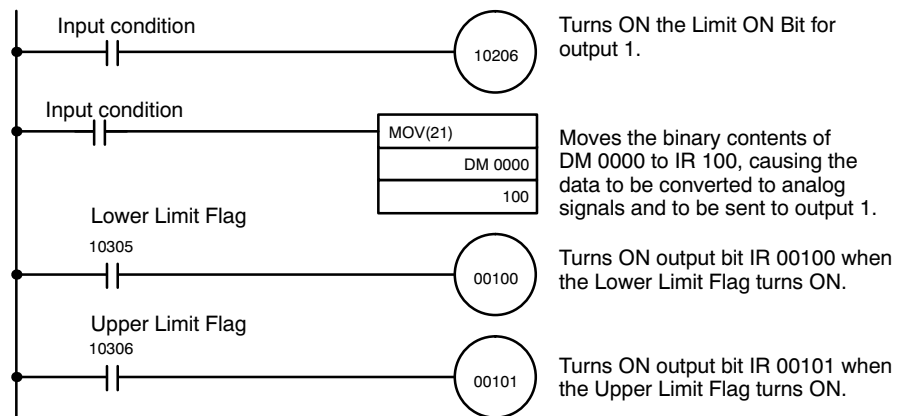

Monitoring Outputs

This example assumes that the data settings given at the beginning of this section have already been made.

Upper and lower limit alarms will be output as described below when the following instructions are executed.

Upper limit alarm: ON when output reaches 19 mA until it drops to 18.5 mA

Lower limit alarm: ON when output falls below 6 mA until it reaches 6.5 mA

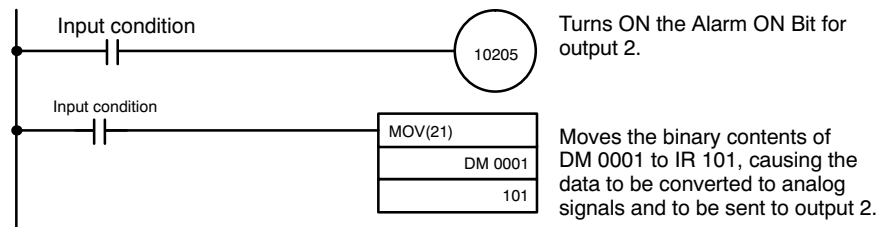

The alarm outputs can be wire externally using external terminals A8 and B8. The ALARM indicator on the Unit will light when any Alarm Flag is ON.

Pulse Output

This example shows how to set pulse outputs on output 1. The pulse output settings are given in the following table.

Item		Value	Data setting
Pulse output	Duty	80%	0CCC in IR 100
	Pulse period	2 s	Turn ON IR 10200

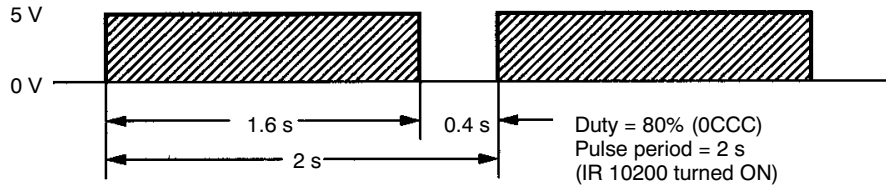

Turn OFF pin 2 (specifying output 1) and turn ON pin 3 (enabling pulse output) on the back-panel DIP switch before starting.

Execute the following instructions in the program. Pulse outputs will be made on output 1.

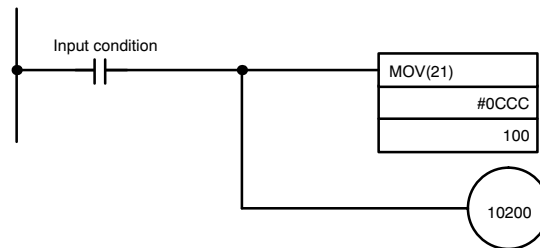

Sets the duty ratio to 80%.

Sets the period at 2 seconds.

3-4 Troubleshooting

Detection When Errors Occur

When an error occurs, the contents are output to the SR and HR areas. The following tables show the various errors that may occur, along with their probable causes and remedies.

Unit error	Probable causes and operations	Possible remedies
Setting error	The data set in the DM area is wrong. In this case, the Setting Error Flag (IR n+3, bit 00) will be ON.	Check the contents of the data.
RUN indicator not lit	The RUN indicator on the Unit is not lit even though power is turned on to the PC, and none of the errors described in this table are applicable.	Replace the Unit.

CPU error	Probable causes and operations	Possible remedies
CPU waiting	<ul style="list-style-type: none"> The Special I/O Unit is defective. The PC will not run. 	<ul style="list-style-type: none"> Replace the Special I/O Unit. The defective Unit should appear as \$ signs only in the I/O table read operation.
Duplicated unit number	The same number is assigned to more than one Special I/O Unit. In this case the PC will not run and SR25415 will turn ON.	Do not assign the same number to more than one Unit. Use the I/O table read operation to display unit numbers.
Special I/O Unit error	An error has occurred in the refresh signal between the CPU and the Special I/O Unit. In this case, only the Special I/O Unit stops. SR 25415 is turned ON.	Check AR 0000 to AR 0009 for the unit number of the Unit in error. After correcting the error, turn ON the proper bit in AR 0100 to AR 0109. If the error does not clear after initialization, replace the Unit.

Special I/O Unit Error Detection Bit (SR)

Bit	Error	Explanation	Operation status
25415	Duplicated unit number	One number is assigned to more than one Special I/O Unit.	PC operation stops.
	Special I/O Unit error	An error has occurred in the refresh signal between the CPU and the Special I/O Unit	Operation stops only for the faulty Unit.

Special I/O Unit Error Flags (AR)

Bit	Item	Function
AR 0000	Unit #0 Error Flag	When one of the CPU errors described above occurs, the AR bit turns ON for the Unit where the error occurred.
AR 0001	Unit #1 Error Flag	
AR 0002	Unit #2 Error Flag	
AR 0003	Unit #3 Error Flag	
AR 0004	Unit #4 Error Flag	
AR 0005	Unit #5 Error Flag	
AR 0006	Unit #6 Error Flag	
AR 0007	Unit #7 Error Flag	
AR 0008	Unit #8 Error Flag	
AR 0009	Unit #9 Error Flag	

Special I/O Unit Restart Bits (AR)

Turn ON the Special I/O Unit Restart Bits in the following circumstances:

- After DM data has been set or replaced.
- To restart Unit operation after clearing an error.

The same effect can be achieved by turning off the power to the PC and then turning it on again.

Bit	Item	Function
AR 0100	Unit #0 Restart Bit	Special I/O Units can be restarted by turning the corresponding bits ON.
AR 0101	Unit #1 Restart Bit	
AR 0102	Unit #2 Restart Bit	
AR 0103	Unit #3 Restart Bit	
AR 0104	Unit #4 Restart Bit	
AR 0105	Unit #5 Restart Bit	
AR 0106	Unit #6 Restart Bit	
AR 0107	Unit #7 Restart Bit	
AR 0108	Unit #8 Restart Bit	
AR 0109	Unit #9 Restart Bit	

Appendix A Standard Models

Analog Output Unit

PC	Model
C200H/C200HS	C200H-DA001

Analog Input Unit

PC	Model
C200H/C200HS	C200H-AD001

Appendix B Specifications

C200H-AD001 Analog Input Unit

General Specifications

All general specifications of the C200H-AD001 Analog Input Unit conform to those of the C Series.

Performance Specifications

Item	Specifications	
Number of analog inputs	4 max.	
Input signal range (note 1)	Voltage input	1 to 5 V
		0 to 10 V
	Current input	4 to 20 mA
Max. input signal (note 2)	Voltage input	□15 V
	Current input	□30 mA
Input impedance	Voltage input	1 MΩ min.
	Current input	250 Ω (rated value)
Resolution	1/4000 max. (full scale)	
Converted data	12-bit binary (0000 to 0FA0)	
Accuracy (note 3)	25°C	□0.5% (full scale, including linearity error)
	0° to 55°C	□1.0% (full scale, including linearity error)
Conversion time (note 4)	2.5 ms max./point	
Isolation	Between input terminals and PC: photocoupler	
	Between input terminals: none	
External connections	19-pin terminal block (removable)	
Power consumption	550 mA max. at 5 VDC	
Dimensions	34.5 x 130 x 128 (W x H x D) mm (see last page of this appendix)	
Weight	450 g max.	

- Note**
1. All points on the same Unit must use the same input range except for the 1 to 5-V and 4 to 20-mA ranges, which can be specified by point.
 2. Operation in ranges beyond the maximum input signals will damage the Unit. Operate within the ranges listed above.
 3. The accuracy is given for full scale (4,000). For example, an accuracy of □5% means a maximum error of 20 (BCD).
 4. This is the time it takes for a full range input signal to be converted and to be stored in the memory of the Unit. It takes at least one scan before the converted data is read by the CPU.

Input Specifications

Converted output data
 (Top: Binary
 Parentheses: BCD)

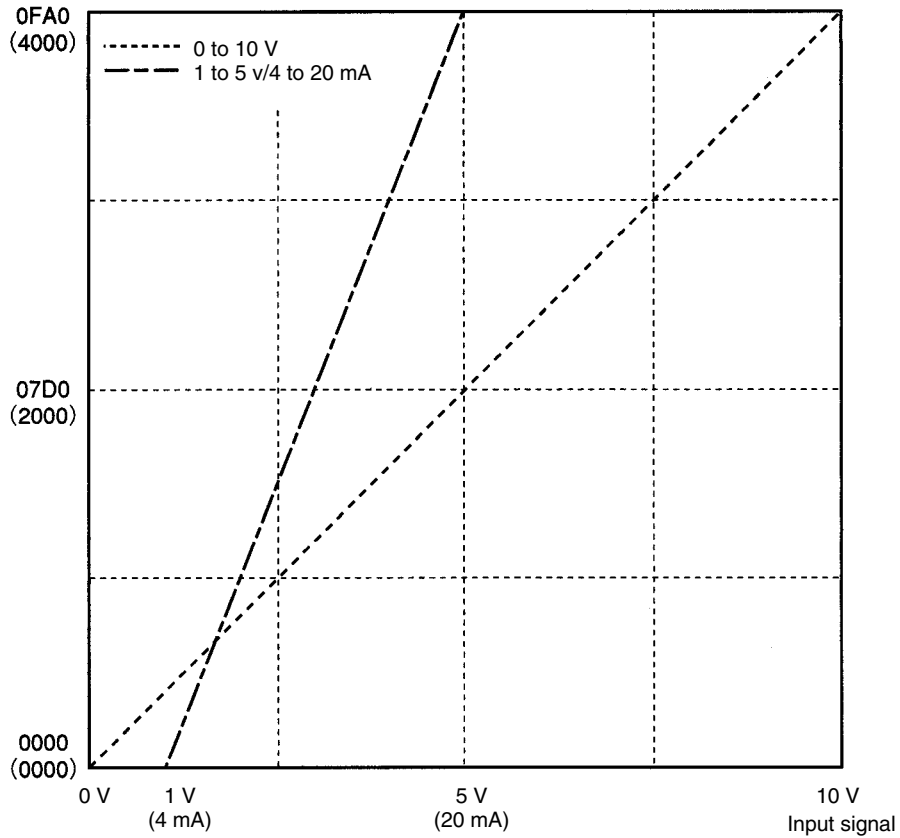

- Note**
1. All points on the same Unit must use the same input range except for the 1 to 5-V and 4 to 20-mA ranges, which can be specified by point. Refer to *2-1-2 Switch Settings* for setting methods.
 2. The maximum or minimum output value will be maintained if the input signals goes beyond the maximum (10 V, 5V, or 20 mA) or minimum (0 V, 1V, or 4 mA).

C200H-DA001 Analog Output Unit

All general specifications of the C200H-DA001 Analog Output Unit conform to those of the C Series.

Item	Specifications	
Number of analog outputs	2	
Output signal range (note 1)	Voltage outputs	1 to 5 V
		0 to 10 V
	Current outputs	4 to 20 mA
Max. output impedance	Voltage output: 0.5 Ω	
Max. output current	Voltage output: 15 mA	
Max. load resistance	Current output: 400 Ω	
Resolution	1/4095 max. (full scale)	
Set data	12-bit binary (0000 to 0FFF)	
Accuracy (note 2)	25°C	$\pm 0.5\%$ max. (full scale, including linearity error)
	0° to 55°C	$\pm 1.0\%$ max. (full scale, including linearity error)
Conversion time (note 3)	2.5 ms max./point	
Isolation	Between output terminals and PC: photocoupler	
	Between output terminals: none	
External connections	19-pin terminal block (removable)	
Power consumption	650 mA max. at 5 VDC	
Dimensions	34.5 x 130 x 128 (W x H x D) mm (see last page of this appendix)	
Weight	450 g max.	

- Note**
1. All points on the same Unit must use the same output range except for the 1 to 5-V and 4 to 20-mA ranges, which can be specified by point.
 2. The accuracy is given for full scale (4,095). For example, an accuracy of $\pm 5\%$ means a maximum error of 20 (BCD).
 3. This is the time from after the data has been written to the Unit until an analog output appears. The output data will not be correct if output data is rewritten faster than it can be output.

Output Specifications

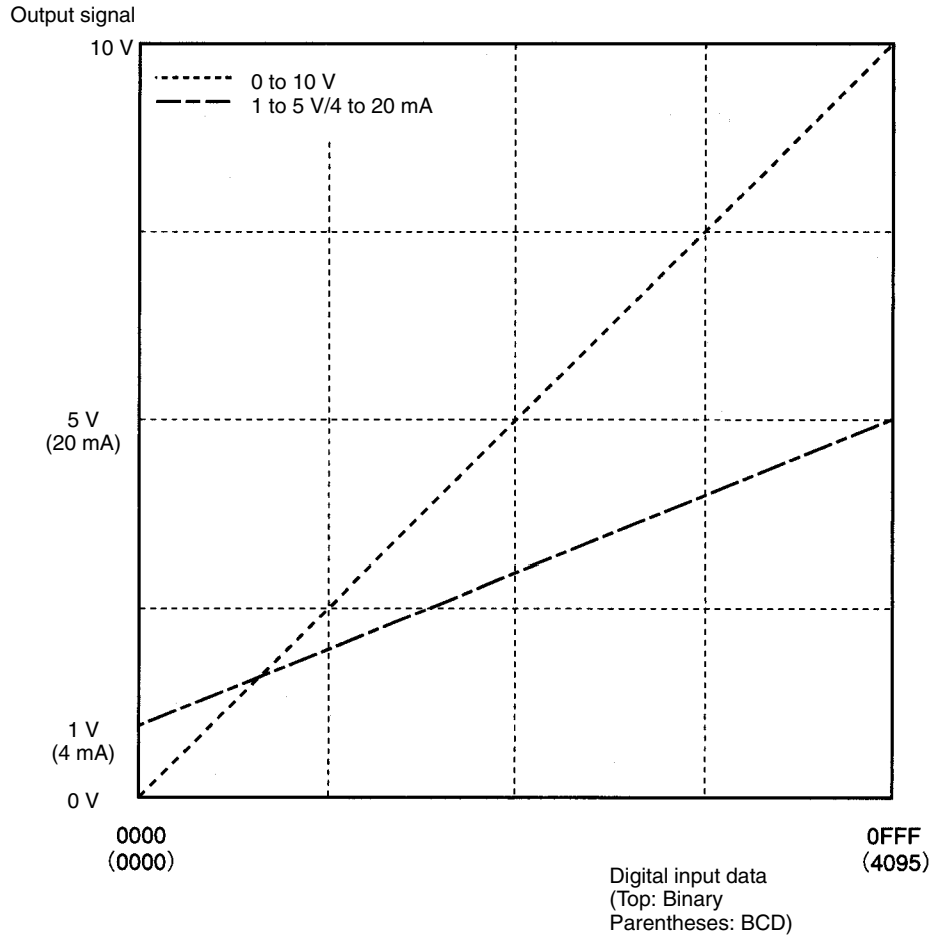

Note All points on the same Unit must use the same output range except for the 1 to 5-V and 4 to 20-mA ranges, which can be specified by point. Refer to 3-1-2 *Switch Settings* for setting methods.

Dimensions (Unit: mm)

The dimensions are the same for both the C200H-AD001 and C200H-DA001.

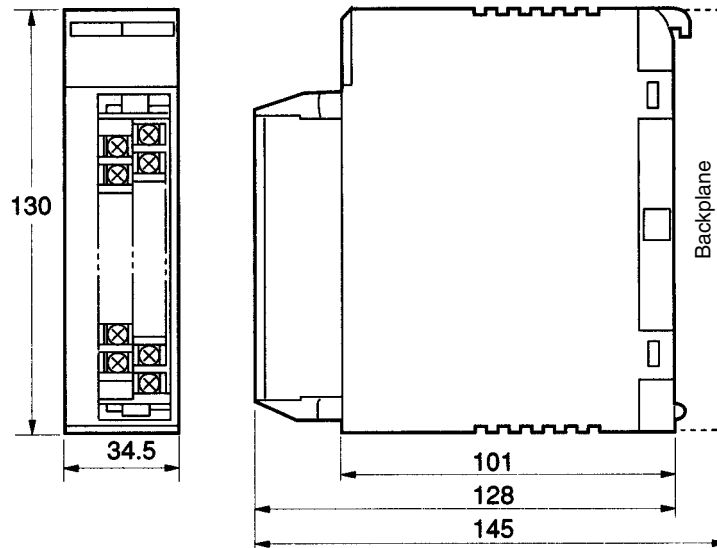

Appendix C

Data Memory Coding Sheets

C200H-AD001 Analog Input Unit

C200H-AD001				Unit number: _____ DM1_00 to DM1_11
DM address (rightmost digits)	Data			Usage
00				Scaling lower limit for input 1
01				Scaling upper limit for input 1
02				Scaling lower limit for input 2
03				Scaling upper limit for input 2
04				Scaling lower limit for input 3
05				Scaling upper limit for input 3
06				Scaling lower limit for input 3
07				Scaling upper limit for input 4
08				Number of terms for mean value for input 1
09				Number of terms for mean value for input 2
10				Number of terms for mean value for input 3
11				Number of terms for mean value for input 4

C200H-DA001 Analog Output Unit

C200H-DA001				Unit number: _____ DM1_00 to DM1_04
DM address (rightmost digits)	Data			Usage
00				Lower output limit
01				Upper output limit
02				Lower alarm limit
03				Upper alarm limit
04				Alarm deadband

Index

A

A/D conversion data, 16
analog input vs. digital output, 19

B—C

block diagram
 C200H-AD001, 9
 C200H-DA001, 31
configurations, system, 4
 considerations, 5

D—F

data memory coding sheet, 53
data reading mode, setting, 11
digital output vs. analog input, 39
dimensions, 52
disconnection detection, 23
DM area allocation
 C200H-AD001, 15, 17
 C200H-DA001, 36, 38
DM area contents, C200H-AD001, 18
field devices, 3

I

indicators
 C200H-AD001, 8
 C200H-DA001, 30
input disconnection detection function, 23
input signal range, setting, 11, 19
inputs
 number, setting, 10
 signal range, setting, 11, 19
IR area allocation
 C200H-AD001, 15, 16
 C200H-DA001, 36, 37
IR area contents
 C200H-AD001, 16
 C200H-DA001, 37

M—N

mean function, 21
models, 47

number of inputs, setting, 10

O

output limit alarm function, 41
output limit function, 39
output signal range, setting, 32, 39
outputs, signal range, setting, 32, 39

P

peak value function, 22
precautions, xi, 2, 5
 applications, xiii
 general, xii
 operating environment, xiii
 safety, xii
programming examples
 C200H-AD001, 24
 C200H-DA001, 43
pulse output function, 42
pulse output line, setting, 33
pulse outputs, setting, 33

S

scaling function, 20
Slave Racks, 5
specifications, 49
square root function, 19
switches
 C200H-AD001, 10
 C200H-DA001, 32

T—W

troubleshooting
 C200H-AD001, 26
 C200H-DA001, 45
unit number, setting, Analog Input Unit, 10
unit numbers, setting
 C200H-AD001, 10
 C200H-DA001, 32
Units, number, 5
wiring
 C200H-AD001, 11
 C200H-DA001, 33

Revision History

A manual revision code appears as a suffix to the catalog number on the front cover of the manual.

Cat. No. W127-E1-4



The following table outlines the changes made to the manual during each revision. Page numbers refer to the previous version.

Revision code	Date	Revised content
3	June 1990	Correction of notation and format. Resource document 29-121D.
3A	November 1993	Page 16: In the Block Diagram, all “inputs” have been corrected to “outputs.” Page 25: The last line of the second paragraph has been corrected.
3B	May 1995	Address change
3C	September 1995	The manual was restructured, expanded, and mostly rewritten.
4	February 2001	The insert providing precautionary information was moved to page 35. A <i>Precautions</i> section was added. In addition, the following changes were made. Pages 4, 5, 15, 18, 24, 36: Changes made to model numbers. Pages 12, 13: Note added.



OMRON ELECTRONICS LLC

1 Commerce Drive
Schaumburg, IL 60173
847.843.7900
For US technical support or
other inquiries: 800.556.6766

OMRON CANADA, INC.

885 Milner Avenue
Toronto, Ontario M1B 5V8
416.286.6465

OMRON ON-LINE

Global - <http://www.omron.com>
USA - <http://www.omron.com/oei>
Canada - <http://www.omron.ca>

UNITED STATES

To locate a Regional Sales Office, local Distributor or
to obtain product information, call: 847.843.7900

CANADA REGIONAL SALES OFFICES

Ontario	Toronto	416.286.6465
	Kitchener	519.896.1144
	Kingston	613.376.3968
Quebec	Montreal	514.636.6676
British Columbia	Vancouver	604.522.8855
Alberta	Edmonton	403.440.0818
	Calgary	403.257.3095

BRAZIL SALES OFFICE

Sao Paulo 55.11.5564.6488

ARGENTINA SALES OFFICE

Cono Sur 54.114.787.1129

MEXICO SALES OFFICES

Florida 954.227.2121 **Ciudad Juarez** 656.623.7083
Mexico, D.F. 555.534.1195 **Monterrey, N.L.** 818.377.4281