

### 1/16 DIN LED Timer with NEMA 4 Protection for a Wide Variety of Applications

- Withstands washdown and dusty environments
- Large, easy-to-read LED displays
- Simple setting with increment and decrement keys
- NEMA 4 rating only when used in conjunction with Y92S-29 rubber gasket, supplied with each unit
- Performs signal ON-delay and cumulative timing



### Ordering Information

Part number	Contact output	H5CL-AD	H5CL-A
	Transistor output (photocoupler)	H5CL-ADS	H5CL-AS
Timing functions	Signal ON-delay and cumulative		
Terminal form	Terminal strip	11-pin round	
Supply voltage	12 to 24 VDC	100 to 240 VAC, 50/60 Hz	

### Model Number Legend

H5CL-A

1 2 3

1. Fixed
2. D: DC supply voltage
3. S: Transistor output

### ■ ACCESSORIES (ORDER SEPARATELY)

Item	Description	Part number
Protective covers	Soft cover	Y92A-48F1
	Hard cover	Y92A-48
	Finger-safe (shock-prevention) terminal cover (DC models only)	Y92A-48T
Track mounting/ front connecting socket	11-pin	P2CF-11
	11-pin, finger-safe type; conforms to VDE 0106/P100	P2CF-11-E
Back connecting socket for panel mounting (See note.)	11-pin	P3GA-11
	11-pin, finger-safe type; conforms to VDE 0106/P100	P3GA-11 (with Y92A-48G)
	Finger-safe terminal cover for P3GA-11 socket	Y92A-48G
Mounting track	50 cm (1.64 ft.) x 7.3 mm (0.29 in.)	PFP-50N
	1 m (3.28 ft.) x 7.3 mm (0.29 in.)	PFP-100N
	1 m (3.28 ft.) x 16 mm (0.63 in.)	PFP100N2
End plate		PFP-M
Spacer		PFP-S
Replacement parts	Rubber gasket (supplied with each unit)	Y92F-29
	Panel mounting adapter (supplied with each unit)	Y92F-30

Note: Y92A-48G is a finger-safe terminal cover for the P3GA-11 socket.

# Specifications

Item	H5CL-A□ (AC models)	H5CL-AD□ (DC models)
Mounting	DIN track, surface, and panel mounting (common)	Panel mounting
External connections	Socket	Screw terminals
Enclosure ratings	Panel surface: IEC IP66 and NEMA Type 4 (indoors) when Y92S-29 rubber gasket is used.	
Digits	4 digits (zero suppress method)	
Max. time settings	9.999 s (0.001-s unit), 99.99 s (0.01-s unit), 999.9 s (0.1-s unit), 9999 s (1-s unit), 99 min 59 s (1-s unit), 999.9 min (0.1-min unit), 99 h 59 min (1-min unit), 999.9 h (0.1-h unit)	
Display modes	Up (increment) and Down (decrement) selectable	
Input signals	Start, gate, reset, and key protection	
Input method	No-voltage input: via NPN transistor or switching of contact	
Operating modes	A (signal ON-delay), F (cumulative operation) selectable	
Reset	Power reset (A (signal ON-delay) mode only), external, manual resets	
Sensor waiting time	216 ms typ., 250 ms max. (Control output is turned OFF and no input is accepted during sensor waiting time.)	
External power supply	50 mA at 12 VDC (±10%)	---
Display	7-segment LEDs (12 mm high, red LEDs for the present value, and 8 mm high, green LEDs for the set value)	
Memory backup	EEP-ROM (overwritten 200,000 times min.), can store data for 20 years min.	
Mounting	DIN track mounting, surface mounting, and panel mounting	Panel mounting
Approvals	UL 508, CSA C22.2 No.14; conforms to EN61010-1	

## ■ RATINGS

Item	H5CL-A□ (AC models)	H5CL-AD□ (DC models)
Supply voltage	100 to 240 VAC, 50/60 Hz	12 to 24 VDC (permissible ripple: 20% (p-p) max.)
Operating voltage range	85 to 264 VAC, 50/60 Hz	10.8 to 26.4 VDC
Power consumption	Approx. 10 VA	Approx. 3 W
Start, reset, gate inputs	Min. pulse width: 1 ms/20 ms (selectable, same for all three inputs)	
Key protection input	Response time: 1 s max.	
Power reset	Min. power opening time: 0.5 s, excluding F (cumulative operation) mode	
Control output	Contact output	SPDT, 3 A at 250 VAC, resistive load ( $\cos\phi = 1$ ); min. applicable load: 10 mA at 5/24 VDC (P level, for reference value);
	Transistor output	NPN open collector, 100 mA max. at 30 VDC max., residual voltage 1.5 VDC max.

## ■ CHARACTERISTICS

Item	H5CL-A□ (AC models)	H5CL-AD□ (DC models)
Repeat accuracy	Power start: $\pm 0.01\% \pm 0.05$ s max. (See Note 1.) Signal start: $\pm 0.005\% \pm 0.03$ s max. (See Note 1.) Signal start, at transistor output model: $\pm 0.005\% \pm 3$ ms max. (See Note 1 and 2.) If the set value is within the sensor waiting time (250 ms max.) in the case of power start, the control output of the H5CL will not be turned ON until the sensor waiting time passes.	
Insulation resistance	100 M $\Omega$ min. (at 500 VDC) (between current-carrying terminal and exposed non-current-carrying metal parts, and between non-continuous contacts)	
Dielectric strength	2,000 VAC, 50/60 Hz for 1 min (between current-carrying terminal and exposed non-current-carrying metal parts) 1,000 VAC, 50/60 Hz for 1 min (between non-continuous contacts)	1,000 VAC, 50/60 Hz for 1 min (between current-carrying terminal and exposed non-current-carrying metal parts, and between non-continuous contacts)
Impulse withstand voltage	3.0 kV (between power terminals) 4.5 kV (between current-carrying terminal and exposed non-current-carrying metal parts)	1.0 kV (between power terminals) 1.5 kV (between current-carrying terminal and exposed non-current-carrying metal parts)
Noise immunity	$\pm 1.5$ kV (between power terminals) $\pm 600$ V (between input terminals), square-wave noise by noise simulator (pulse width: 100 ns/1 $\mu$ s, 1-ns rise)	$\pm 480$ kV (between power terminals) $\pm 600$ V (between input terminals), square-wave noise by noise simulator (pulse width: 100 ns/1 $\mu$ s, 1-ns rise)
Static immunity	Destruction: 15 kV Malfunction: 8 kV	
Vibration resistance	Destruction: 10 to 55 Hz, 0.75-mm single amplitude each in three directions Malfunction: 10 to 55 Hz, 0.5-mm single amplitude each in three directions	
Shock resistance	Destruction: 294 m/s <sup>2</sup> (30G) each in three directions Malfunction: 98 m/s <sup>2</sup> (10G) each in three directions	
Ambient temperature	Operating: -10 to 55°C (14 to 131°F) with no icing; if timers are mounted side-by-side: -10 to 50°C (14 to 122°F) with no icing Storage: -25 to 65°C (-13 to 149°F) with no icing	
Ambient humidity	Operating: 35% to 85%	
Service life	Mechanical: 10,000,000 operations min. Electrical: 100,000 operations min. (3 A at 250 VAC, resistive load)	
EMC	(EMI): EN50081-2 Emission Enclosure: EN55011 Group 1 class A Emission AC Mains: EN55011 Group 1 class A (EMS): EN50082-2 Immunity ESD: EN61000-4-2: 4 kV contact discharge (level 2) 8 kV air discharge (level 3) Immunity RF-interference: ENV50140: 10 V/m (80 MHz to 1 GHz) (level 3) Immunity Conducted Disturbance: ENV50141: 10 V (0.15 to 80 MHz) (level 3) Immunity Burst: EN61000-4-4: 2 kV power-line (level 3) 2 kV I/O signal-line (level 4)	
Materials	Case: plastic (Munsell 5Y7/1), light gray	
Weight	Approx. 130 g	Approx. 110 g

Note: 1. The values are based on the set value.

2. The value is applied for a minimum pulse width of 1 ms.

# Nomenclature

## Indicator

1. Present Value  
Red LEDs with a character height of 12 mm

Note: The decimal point will flash on the present value during the timing operation in the following ranges:  
0.1 to 999.9 min, 0 h 01 min to 99 h 59 min, and  
0.1 to 999.9 h.

2. Preset Value  
Green LEDs with a character height of 8 mm
3. Reset Indicator (orange)
4. Key Protection Indicator (orange)
5. Time Unit Display (orange)
6. Control Output Indicator (orange)

## Operation Key

7. Reset (RST) Key  
The RST Key initializes the present value and control output.
8. Increment Keys (1 to 4)  
Up Keys 1 to 4 increment the preset value.
9. Decrement Keys (1 to 4)  
Down Keys 1 to 4 decrement the preset value.

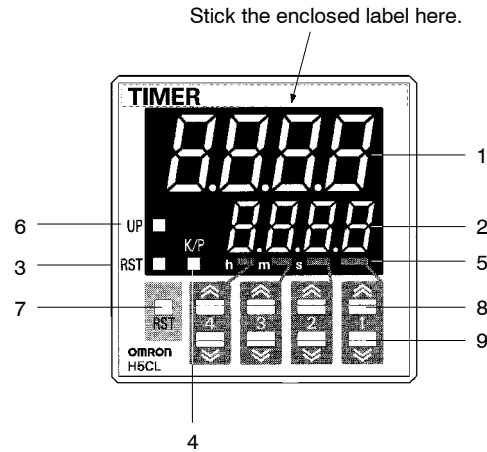

# Operation

## ■ DIP SWITCH SETTING

Pin no.	Item	OFF	ON
1, 2, 3	Time ranges	See table below.	
4	Display modes	Up (Increment)	Down (Decrement)
5	Min. pulse width of inputs	20 ms	1 ms
6	Operating modes	A (signal ON-delay)	F (cumulative operation)

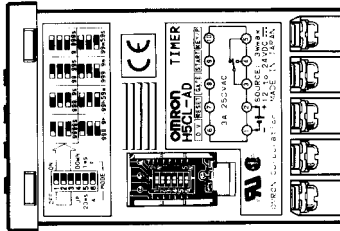

- Switches 1 to 6 are all set to OFF before shipping.
- The same switch settings apply to AC and DC models.
- Set the DIP switch before installation and operation of the unit.
- DIP switch setting changes made while the power is ON cannot take effect.

## Time Ranges

1	2	3	Time range
ON	ON	ON	0.001 to 9.999 s
OFF	OFF	OFF	0.01 to 99.99 s
ON	OFF	OFF	0.1 to 999.9 s
OFF	ON	OFF	1 to 9999 s
ON	ON	OFF	0 min 01 s to 99 min 59 s
OFF	OFF	ON	0.1 to 999.9 min
ON	OFF	ON	0 h 01 min to 99 h 59 min
OFF	ON	ON	0.1 to 999.9 h

## Timer Control with Power Start

When using the H5CL with power start, short-circuit the start input and input 0-V terminals.

■ OPERATING MODES

**A Mode**  
Signal ON-delay

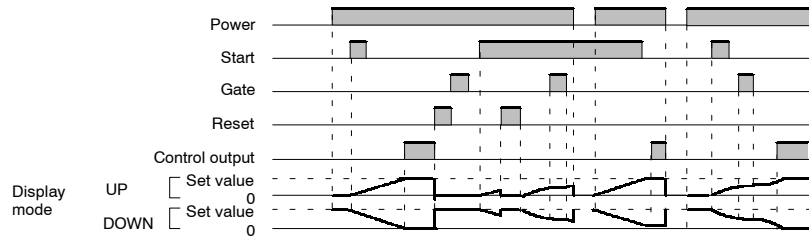

**F Mode**  
Cumulative Operation

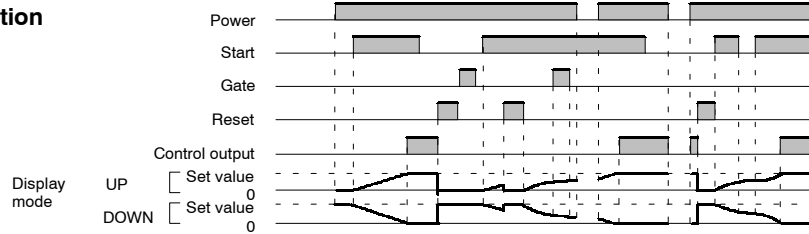

Dimensions

Unit: mm (inch)

■ H5CL-A□

DIN Track/Surface/Panel Mounting (AC Versions)

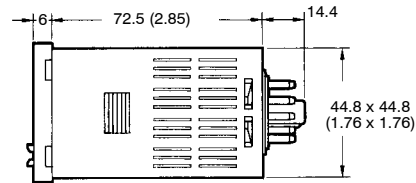
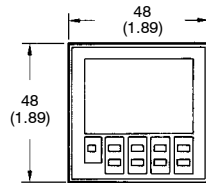
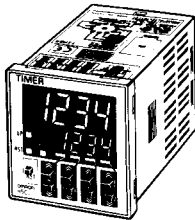

■ H5CL-AD□

Panel Mounting (DC Versions)

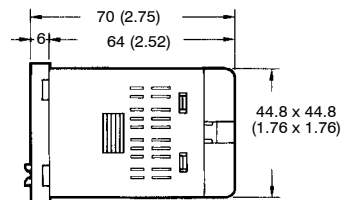
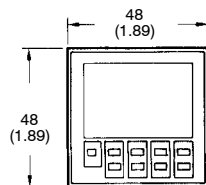
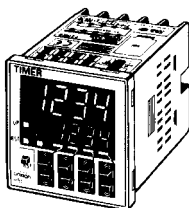

■ H5CL-A□

With Panel Mounting Adapter

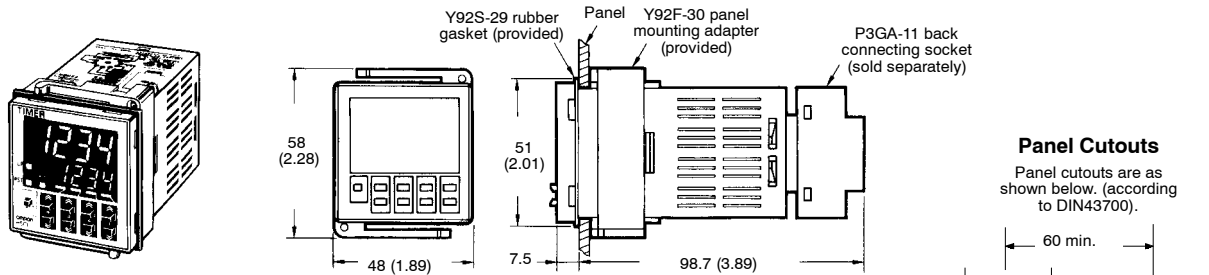

**Panel Cutouts**  
 Panel cutouts are as shown below. (according to DIN43700).

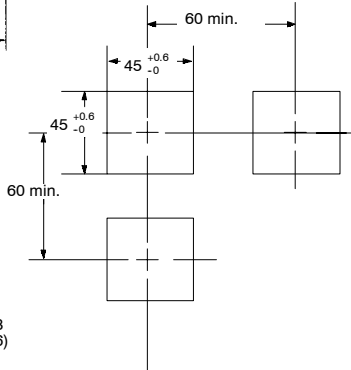

■ H5CL-AD□

With Panel Mounting Adapter

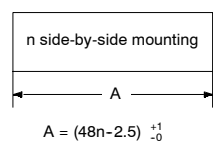
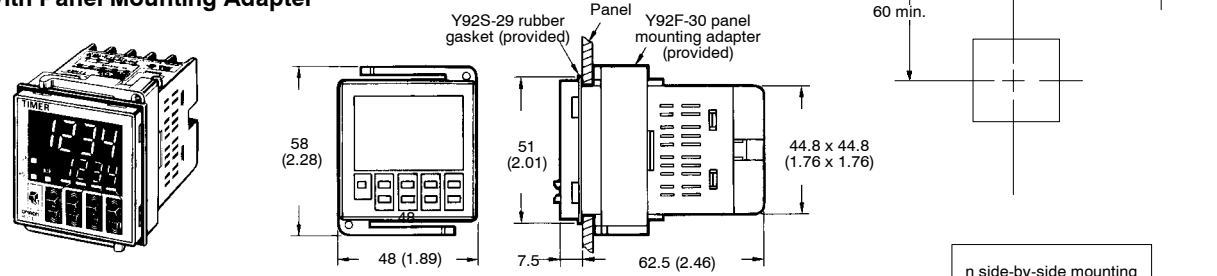

- Note: 1. The mounting panel thickness should be 1 to 4 mm.  
 2. It is possible to mount timers side by side, but only in one direction.  
 3. When the Timers are mounted closely side by side, the Timers will not be water-resistant.

**H5CL-A□ Timer with Front-Connecting P2CF-11 (-E) Socket  
 DIN Track Mounting**

Note: See P2CF-11 Socket in *Accessories* (order separately).

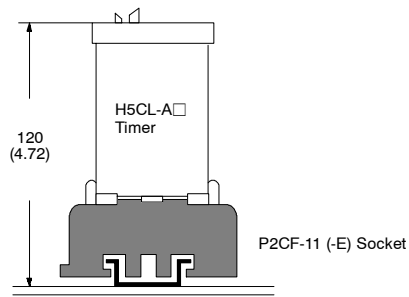

■ ACCESSORIES (ORDER SEPARATELY)

**P2CF-11 Track Mounting/Front-Connecting Socket**

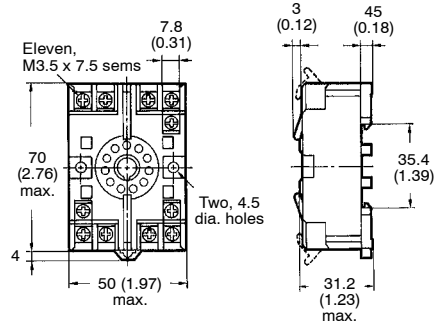
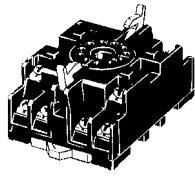

**Terminal Arrangement/  
Internal Connections  
(Top View)**

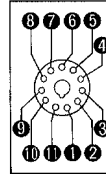

**Surface Mounting Holes**

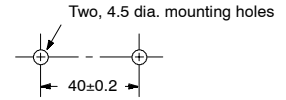

**P2CF-11-E (Finger-Safe Terminal Type)  
Conforming to VDE0106/P100**

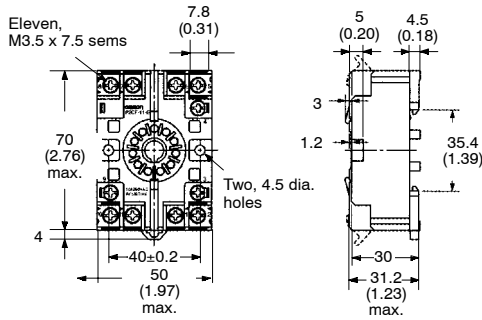
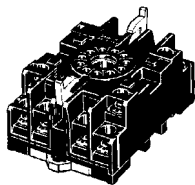

**P3GA-11  
Back-Connecting Socket**

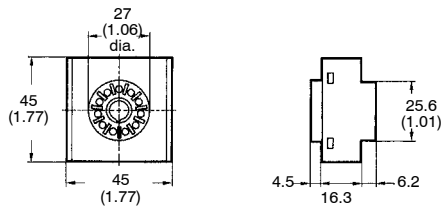
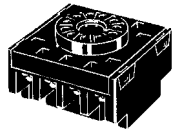

**Terminal Arrangement/  
Internal Connections  
(Bottom View)**

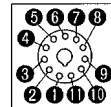

**Finger-Safe Terminal Covers**  
Conforming to VDE0106/P100

**Y92A-48G**  
Attachment for P3GA-11 Socket

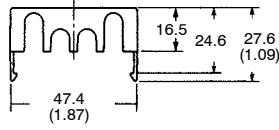
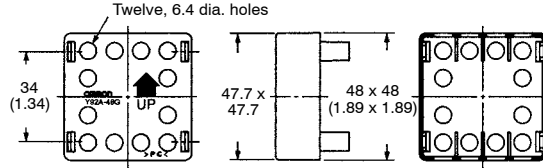
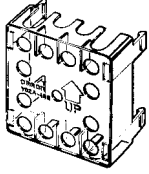

**Y92A-48T**  
Attachment for H5CL DC Models

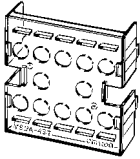

**Hard Cover**  
Y92A-48

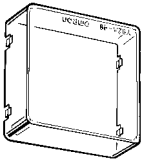

**Soft Cover**  
Y92A-48F1

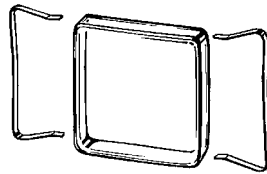

**■ MOUNTING TRACK**

**PFP-100N/PFP-50N**

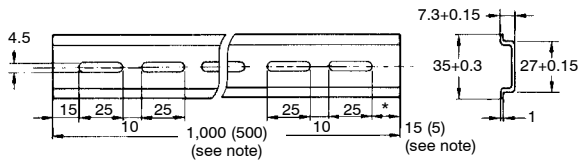
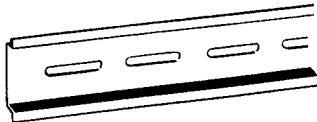

**PFP-100N2**

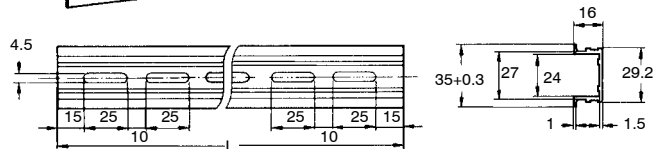
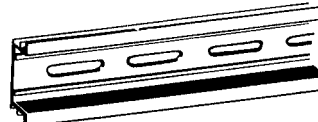

Note: The values shown in parentheses are for the PFP-50N.

# Installation

## ■ TERMINAL ARRANGEMENT

### AC Models

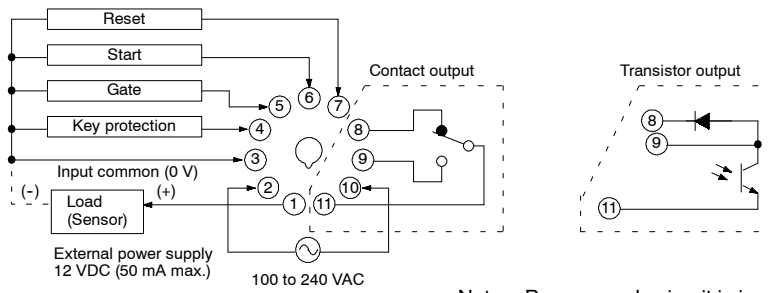

Note: Power supply circuit is insulated from the internal circuit (or I/C)

### DC Models

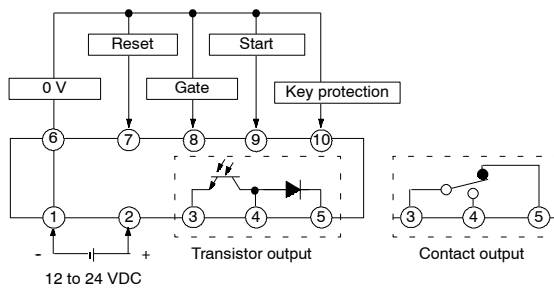

Note: 1 and 6 are connected to each other internally.

INPUT CIRCUITS

Start, Reset, and Gate Input  
H5CL-A□ (AC Models)

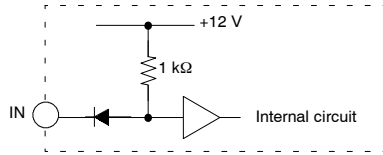

H5CL-AD□ (DC Models)

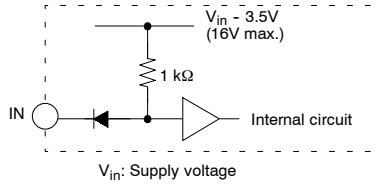

Key Protection Input

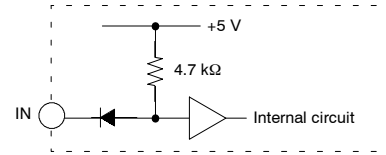

Note: No key input is effective while key protection input is ON.

INPUT CONNECTIONS

Open Collector Output

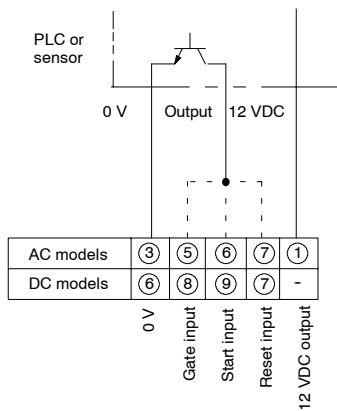

Voltage Output

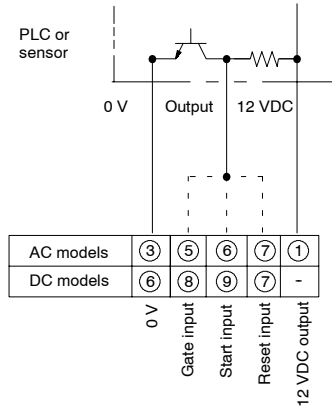

Contact Input

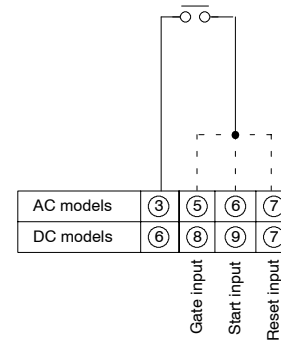

Start, Reset, and Gate Input Specification

ON impedance: 500 Ω max. (the leakage current is 5 to 20 mA when the impedance is 0 Ω.)  
 ON residual voltage: 2 V max.  
 OFF impedance: 100 kΩ min.  
 Maximum applicable voltage: 30 VDC max.

Two-Wire Sensor

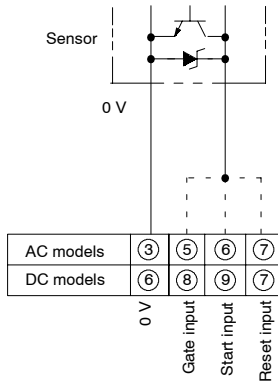

Applicable Two-Wire Sensor

Leakage current: 1.5 mA max.  
 Switching capacity: 5 mA min.  
 Residual voltage: 3 V max.  
 Operating voltage: 10 VDC

Note: When connecting a two-wire sensor to a DC models, supply 24 VDC (21.6 to 26.4 VDC) to the timer.

Key Protection Input

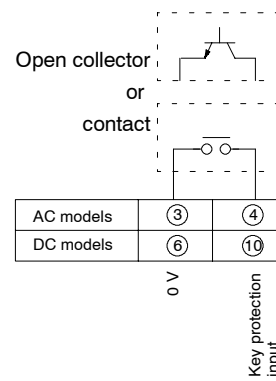

Key Protection Input

ON impedance: 1 kΩ max.  
 (the leakage current is approx. 1 mA when the impedance is 0 Ω.)  
 ON residual voltage: 0.5 V max.  
 OFF impedance: 100 kΩ min.  
 Maximum applicable voltage: 30 VDC max.

Note: The used contact should switch 1 mA at 5 V.

## Precautions

### POWER SUPPLIES

When turning the power ON and OFF, input signal reception is possible, unstable, or impossible (as shown here).

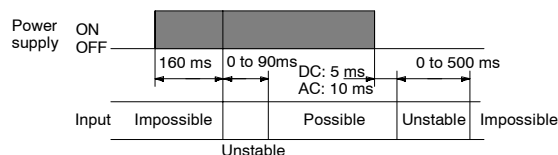

Apply the power supply voltage through a relay or switch so that that the voltage reaches a fixed value immediately.

Turn the power ON and OFF with relay with a rated capacity of 10 A minimum to prevent contact deterioration due to inrush current caused by turning the power ON and OFF.

### TIMER CONTROL WITH POWER START

The timer will function 160 to 250 ms after the power is turned ON (refer to the above diagram). The control output will be delayed for any set value less than 250 ms.

When the H5CL is used with power start in F mode (i.e., cumulative operation with output on hold), there will be a timer error (approximately 100 ms each time the H5CL is turned on) due to the characteristics of the internal circuitry. Use the H5CL with signal start if timer accuracy is required.

### TRANSISTOR OUTPUT

The transistor output of the H5CL is insulated from the internal circuitry by a photocoupler, so the transistor output can be used as both NPN and PNP output.

The diode connected to the collector of the output transistor is used to absorb inverted voltage that is generated when an inductive load is connected to the H5CL.

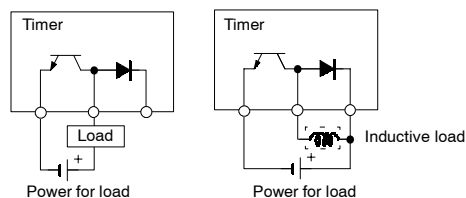

### SELF-DIAGNOSTIC FUNCTION

The following displays will appear if an error occurs.

Display	Error	Output status	Correction	Set value after correction
E1	CPU	OFF	Press RST Key or turn power off and then ON	No change
E2	Memory (See Note.)			0

Note: This includes times when the life of the EEPROM has expired.

### OPERATING ENVIRONMENT

When using the Timer in an area with excess electrical noise, separate the Timer, wiring, and the equipment which generates the input signals as far as possible from the noise sources. We recommend shielding the input signal wiring to prevent electrical interference. Organic solvents (such as paint thinner), as well as very acidic or basic solutions can damage the outer casing of the Timer.

### CHANGING THE PRESET VALUE

When changing the preset value during a timing operation, output will turn ON if the preset value is changed as follows (since the constant read-in system is in use):

Display mode UP: Present value  $\geq$  preset value  
 Display mode DOWN: Elapse time  $\geq$  preset value  
 (Present value = 0)

Note: When in down mode, the changed amount of preset value is added to or subtracted from the present value.

#### Reset with a Preset Value of 0

The output will go ON when the start signal is input. The output will be OFF while the reset key is pressed or the reset input is ON.

### MEMORY BACKUP

All data is stored in the EEPROM when there is power failure. The EEPROM can be overwritten more than 200,000 times.

Operating mode	Overwriting timing
A mode	When the H5CL is turned off after changing the set value.
F mode	When the H5CL is turned off after changing the set value, turning the start input, or the reset input ON.

### PANEL MOUNTING

The H5CL's panel surface is water-resistant, conforming to NEMA 4 (indoors) and IP66. In order to prevent the internal circuit from water penetration through the space between the timer and operating panel, attach a rubber packing (provided with the H5CL) between the timer and operating panel and secure the rubber gasket with the Y92F-30 panel-mounting adapter.

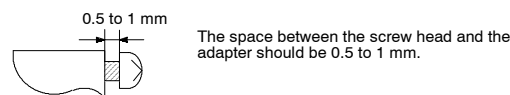

### AVOID DAMAGE WHEN TESTING

When performing a dielectric strength test (or similar test) on the H5CL mounted to a control panel, disconnect the H5CL from the connecting circuit, or short-circuit all the terminals of the H5CL to avoid damaging the H5CL.

### INTERNAL CONNECTIONS FOR DC MODEL

Terminal 1 (power supply terminal) and terminal 6 (input common: 0 V for input) of DC model H5CL are internally connected to each other.

### DIP SWITCH SELECTION

DIP switch setting while the H5CL is turned on will not be valid until the H5CL is turned off and on.

NOTE: DIMENSIONS SHOWN ARE IN MILLIMETERS. To convert millimeters to inches divide by 25.4.

**OMRON**<sup>®</sup>

**OMRON ELECTRONICS LLC**

One East Commerce Drive  
Schaumburg, IL 60173

**1-800-55-OMRON**

**OMRON ON-LINE**

Global - <http://www.omron.com>  
USA - <http://www.omron.com/oei>  
Canada - <http://www.omron.com/oci>

**OMRON CANADA, INC.**

885 Milner Avenue  
Scarborough, Ontario M1B 5V8

**416-286-6465**